

NES NORDIC ELECTRIC POWER CO- OPERATION	TECHNICAL SPECIFICATION FROM THE NES GROUP	TS 02 PAGES: 87 ENCLOSURES: 9 DATE: 01.03.2011
---	---	--

**Requirements on rolling stock
in Norway and Sweden
regarding EMC with the
electrical infrastructure and
coordination with the power
supply and other vehicles**

TABLE OF CONTENTS

1	EXECUTIVE SUMMARY	4
1.1	GENERAL CHARACTERISTICS.....	4
1.2	TECHNICAL REQUIREMENTS	4
1.2.1	<i>Signal interference and telecommunication.....</i>	4
1.2.2	<i>Power supply compatibility.....</i>	5
1.3	APPROVAL PROCEDURES AND TESTS.....	6
1.4	DELIVERABLES.....	7
2	INTRODUCTION	8
2.1	ABSTRACT	8
2.2	ABOUT THIS DOCUMENT	9
2.2.1	<i>Structure</i>	9
2.2.2	<i>Validity.....</i>	9
2.2.3	<i>Responsibility.....</i>	9
2.2.4	<i>Coordination between sections and document versions.....</i>	9
2.2.5	<i>National differences.....</i>	9
2.2.6	<i>Accuracy</i>	10
2.3	ABBREVIATIONS AND DEFINITIONS	10
2.3.1	<i>Abbreviations</i>	10
2.3.2	<i>Definitions.....</i>	11
2.4	SCOPE	12
2.5	GENERAL INFORMATION ABOUT THE INFRASTRUCTURE	14
2.5.1	<i>General</i>	14
2.5.2	<i>Norway.....</i>	14
2.5.3	<i>Sweden.....</i>	15
2.6	REVISION HISTORY	16
3	SIGNALLING SYSTEMS AND TELECOMMUNICATION	17
3.1	REFERENCES.....	17
3.1.1	<i>Normative references.....</i>	17
3.1.2	<i>Other references</i>	18
3.2	COMPATIBILITY REQUIREMENTS	19
3.2.1	<i>S1: DC track circuits</i>	19
3.2.2	<i>S2: 95 Hz and 105 Hz track circuits (Norway only)</i>	22
3.2.3	<i>S3: TI 21 track circuits (Norway only)</i>	23
3.2.4	<i>S4: FTGS track circuits (Norway only)</i>	24
3.2.5	<i>S5: Telecommunication disturbances and psophometric currents.....</i>	26
3.2.6	<i>S6: Broad-band interference (Norway only).....</i>	27
3.2.7	<i>S7: Radiated interference</i>	28
3.2.8	<i>S8: Outside antennas on vehicles.....</i>	29
3.2.9	<i>S9: Resistance between wheelsets.....</i>	30
3.3	VALIDATION AND TESTS	31
3.3.1	<i>Requirements prior to tests</i>	31
3.3.2	<i>Coordination with tests regarding compatibility with the power supply</i>	32
3.3.3	<i>General test program.....</i>	33
3.3.4	<i>Test details.....</i>	34
3.3.5	<i>Measurement instrumentation and methods</i>	37
3.4	DOCUMENTATION.....	41
3.4.1	<i>General.....</i>	41
4	POWER SUPPLY	42

APPENDICES	51 PAGES
APP. 1: INFRASTRUCTURE DATA AND RELATED INFORMATION	27 PAGES
APP. 2: NETWORK MAP OF NORWAY	1 PAGE
APP. 3: NETWORK MAP OF SWEDEN	2 PAGES
APP. 4: ADDITIONAL INFORMATION FOR STABILITY STUDIES	4 PAGES
APP. 5: DYNAMIC BEHAVIOUR FOR ROTARY CONVERTERS	19 PAGES
APP. 6: TYPICAL CROSS SECTION OF A BOOSTER TRANSFORMER LINE IN SWEDEN	1 PAGE
APP. 7: CROSS SECTION OF EXISTING AT-SYSTEM LINES IN SWEDEN	1 PAGE
APP. 8: CROSS SECTION OF NEW STANDARD FOR AT-SYSTEM LINES IN SWEDEN	1 PAGE
APP. 9: PSOPHOMETRIC WEIGHTING FACTORS ACCORDING TO ITU-T	2 PAGES

1 EXECUTIVE SUMMARY

The international standards EN 50 121, EN 50 163, EN 50 238, EN 50 388, and others, define the framework for the electrical compatibility between the rolling stock and the infrastructure systems on electrified railways. However, since the infrastructure systems for historical reasons are not equal in all countries, each national rail administration must define the detailed application of the standards in that country, and specify additional requirements in fields that are not covered by the standards. The present document defines the details of the electrical railway infrastructure in Norway and Sweden, and specifies the electrical compatibility requirements for the rolling stock. In general, these requirements are in accordance with the relevant standards, but certain technical differences exist, also compared to the systems in the other 16.7 Hz countries Germany, Austria, and Switzerland.

1.1 General Characteristics

The following is a prioritized list of the problems and general system characteristics that have typically caused train suppliers the greatest difficulties when introducing a new vehicle in the Norwegian and/or Swedish railway network:

1. Low frequency power oscillations, when supplied from rotating converters
2. High levels of line voltage distortion, in particular the 3rd and 5th voltage harmonics, and high crest voltages
3. Regenerative braking and line voltage limitation
4. Power factor control for improvement of the power capacity of weak supply lines
5. The weak power supply in general, characterized by long feeding distances, single-track lines, small rotating as well as static 50 Hz to 16 2/3 Hz converter stations, and a high number of phase-angle controlled vehicles

1.2 Technical Requirements

1.2.1 Signal interference and telecommunication

Ref.	System	Requirement / interference limit	Details
S1	DC (S only)	25 A, and limits for the DC component at transformer inrush.	3.2.1
S2	95 Hz and 105 Hz (N only)	1.00 A. Monitoring required.	3.2.2
S3	TI21 track circuits (N only) 16 bands 1532 Hz to 2610 Hz	TBD A	3.2.3
S4	FTGS track circuits (N only) 4 bands 4.75 kHz to 6.25 kHz 8 bands 9.5 kHz to 16.5 kHz	1.00 A 0.50 A	3.2.4
S5	Psophometric currents	1.50 A	3.2.5
S6	Broad-band (N only) TBD-7 kHz 7-9 kHz > 9 kHz	1.00 A 0.50 A 0.33 A	3.2.6
S7	Radiated interference	According to EN 50 121-3-1	3.2.7
S8	Outside antennas	According to EN and BVS standards.	3.2.8
S9	Resistance between wheelsets	< 0.1 Ω.	3.2.9

1.2.2 Power supply compatibility

Ref.	System	Characteristics / requirements	Details
P1	Line voltage levels	$U_{\min 2} = 10 \text{ kV}$ (N only). Voltage jumps may occur at any level between $U_{\min 2}$ and $U_{\max 2}$.	4.3.1
P2	Line voltage frequency	The line frequency is 16 2/3 Hz. The railway power supply is synchronized to the 50 Hz mains.	4.3.2
P3	Line voltage distortion	The line voltage may be heavily distorted, with up to 5 kV 3 rd and 5 th harmonic. The crest voltage may exceed 30 kV.	4.3.3
P4	Neutral sections	Procedural requirements for the loco driver.	4.3.4
P5	Power factor (cos(ϕ))	The limits for cos(ϕ) are more strict, compared to EN 50 388. It is generally only possible to regenerate any significant power back into the weak supply system, if a power factor (cos(ϕ)) control is applied.	4.3.5
P6	Maximum line current limitation	Procedural requirements for the loco driver.	4.3.6
P7	Current or power control at low line voltage	The power control specified by EN 50 388 is of particular importance due to the weak supply.	4.3.7
P8	Low frequency power oscillations	The rotating converters have a poorly damped eigen-frequency at approximately 1.6 Hz. The vehicles must not cause the system to become unstable at any condition.	4.3.8
P9	Electrical resonance stability	The input admittance of the vehicles must be passive at all frequencies > 90 Hz.	4.3.9
P10	Current harmonics	The limits for the 3 rd , 5 th , 7 th , and 9 th current harmonic are 5.0%, 3.0%, 3.0%, and 3.0%, respectively, of the rated current of the vehicle.	4.3.10
P11	Relay coordination	In accordance with EN 50 388.	4.3.11
P12	Transformer inrush (AC)	The peak inrush current must be < 2.00 kA.	4.3.12
P13	Regenerative braking	The vehicle must not cause the line voltage to increase above 17.5 kV (S) or 18.0 kV (N), in regenerative braking. The vehicle must not cause the voltage locally at other types of vehicles to exceed 17.5 kV to any greater extent than what is seen in the existing system (S only).	4.3.13
P14	Train heating	In accordance with UIC standards. Inrush tests required.	4.3.14
P15	Energy measurement	The ERESS (European Railway Energy Settlement System) system is used.	4.3.15
P16	Other electrical equipment	Certain requirements regarding equipment in the driver's cab.	4.3.16
P17	Ice on the overhead line	Significant DC levels have been measured in the primary currents of existing vehicles at OHL ice conditions.	4.3.17

1.3 Approval Procedures and Tests

The table below outlines the tests that are required for approval. The time needed for the tests depend on a) the number of different operation modes for the vehicle, and b) the free time on the closed track the actual time periods for testing. Most tests must be performed night-time. Experience shows that the categories T1 and T2 require at least two nights each plus transport time, and category T3 1-2 days. In Sweden, category T4+T5 is generally also one day due to the transport. It is expected that category T6 is performed at the suppliers workshop or similar facilities.

It should be noted that these approximate time indications are valid only for a vehicle that is *in its final and approvable state, with all software functions and all parameters frozen*. Any tests required for the supplier's own purposes (i.e., to make the vehicle approvable, or for fine-tuning of software) come in additional and up front.

The test categories T1, T2, and T4 may be performed in either country. The mixed traffic tests T3 must be performed in the country/countries where the vehicle will operate. Test T5 must be performed in Sweden. The tests T6 may be performed anywhere with 16 2/3 Hz or 16.7 Hz supply. For an approval in Norway, parallel measurements in the substation must be made during test T1.

Three different acceleration-brake operation sequences are defined: LOOP, ABAB, and ARO (please refer to section 3.3.4 and 4.4.4).

Cat.	Condition	Suitable test sites	Scope and train operation	Max. line speed
T1	Closed track, rotating converters	Alvesta-Emmaboda (S) Hønefoss-Nesbyen (N)	S1-S6 (LOOP) P1, P2, P5-P10, P13 (ABAB, ARO)	< 130 km/h
T2	Closed track, static converters	Eskilstuna-Södertälje (S) Gardermoen line (N)	S1-S6 (LOOP) P1, P2, P5-P10, P13 (ABAB, ARO, voltage jump)	200 km/h
T3	Mixed traffic	Borlänge area (S) Oslo area (N)	S1-S6, P1-P3, P5-P10, P13 (Normal operation)	
T4	Transformer inrush (peak AC)	Ockelbo (S) Oslo S (N)	P12	
T5	Transformer inrush (DC, S only)	Ockelbo (S)	S1	
T6	Other tests	Any possible	S7, P14	
T7	Non-test approval	N/A	S8, S9, P4, P11, P15-P17	

All vehicles must perform tests up to their speed limit during test category T2. Locomotives must be loaded by a reasonably heavy train ($\approx 1-2$ t per kN max. tractive effort, or $\approx 50-100$ t per MW max. power, whichever is the greater) during all tests T1 and T3, in order to create realistic acceleration times. During tests T2, a somewhat lighter load may be used (some 25% of the values above).

1.4 Deliverables

The supplier must deliver the following documents and other information regarding electrical compatibility.

Before testing:

- Clause-by-clause comments to the present specification section 3 and 4, explaining how the technical requirements are met
- Calculated, previously measured, or otherwise estimated signaling interference and psophometric current levels
- The input admittance versus frequency characteristics
- A simulation study regarding low frequency power oscillations
- Descriptions and characteristics of key functions, such as the current or power control at low line voltages, voltage limitation at regenerative braking, $\cos(\varphi)$ -control, etc.
- Calculations regarding the voltages locally at other types of vehicles (S only)
- Design descriptions, main circuit diagrams, data sheets, and other relevant general information
- Test reports and other documentation showing that the vehicle meets the radiated interference requirements of EN 50 121-3
- Documentation that the vehicle is compatible with relevant requirements outside the field of EMC (such as running dynamics, kinematic envelope, braking performance, etc.), to obtain track access for the EMC tests
- A test plan, including descriptions of the instrumentation and data analysis

After testing:

- The test report, including individual conformity statements for each requirement S1-S9 and P1-P16, and including explanations, references to the detailed test results and printouts, and so on.

Before operation:

- Vehicle data for power system studies

2 INTRODUCTION

2.1 Abstract

The international standards (EN, IEC, UIC, etc.) that deal with electromagnetic and functional compatibility between railway vehicles and infrastructure, are kept on a quite general level and do not cover all aspects of relevance for each individual country and national rail administration. Typically, different signalling systems are used in different countries, meaning that specific national requirements apply in addition to the common standards.

In Norway and Sweden, not only the signalling systems, but also the power supply differs significantly in comparison with other 16.7 Hz countries.

It is the objective of the present document to compile all relevant information and all requirements that apply to rolling stock used in Norway and Sweden, with respect to compatibility with the electrical infrastructure and other vehicles; i.e. the power supply, existing rolling stock, and infrastructure systems such as track signalling circuits, telecommunication lines, etc.

Jernbaneverket and Banverket are committed to harmonize, as far as possible, not only their technical requirements, but also their requirements regarding approval procedures and tests. It must be noted, however, that due to a number of technical differences between the two countries, this objective cannot be fulfilled for all requirements.

The document is first and foremost based on the standards EN 50 121 part 1 to 5, EN 50 163, EN 50 238 and EN 50 388. This however does not imply that other standards are not valid.

The document concentrates on the special national conditions that are valid for Norway or Sweden, and on topics that are not completely covered by international standards.

The tests described in the document are considered being type tests. This means that if tests are performed in one country, and the test procedures and conditions are representative also for the other country, then the tests, the recorded data, and the results may also be used for the performance evaluation and approval in the other country, even if the limits are different (i.e., tests in one country can provide data also for the other country).

Requirements regarding the mechanical interaction between the pantograph and the contact line are presented in other documents. Furthermore, the requirements on train control systems, such as ATC (= Automatic Train Control) or ERTMS, and interference with train radio and digital systems such as PCM, ISDN, etc., are not included in this document.

2.2 About this document

2.2.1 Structure

This document exists in three versions:

- One full version with all sections 1-4. This version is an appendix to Banverkets document BVS 543:19300.
- One version with the sections 1-3 only, and section 4 left unused. This version is an appendix to chapter 5 in Jernbaneverkets document JD 590.
- One version with the sections 1, 2, and 4 only, and section 3 left unused. This version is an appendix to chapter 4 in Jernbaneverkets document JD 590.

2.2.2 Validity

Section 1 and 2 of this document are for information only. The formal and valid requirements are given in section 3 and 4. In case of any conflicts, section 3 and 4 take precedence over section 1 and 2.

2.2.3 Responsibility

Section 3 of this document is under the responsibility of the signalling departments at Jernbaneverket and Banverket, while the power supply departments are responsible for section 4.

2.2.4 Coordination between sections and document versions

Certain parts of section 3 and 4 are harmonised and to some extent equal, in particular the requirements regarding testing. These sections are marked with a vertical line in the left margin, as shown here. Any changes to these sections should be coordinated between the signalling and the power supply departments.

2.2.5 National differences

Most requirements apply equally in the two countries. If a requirement is valid solely in one country, this is highlighted with a (Norway only) or (Sweden only) in the level three header for that requirement. Sometimes (e.g., in tables), the shorter (N only) or (S only) is used.

If a requirement is different in the two countries, the following identification is made:

NORWAY AND SWEDEN:

Here the parts of the requirement that are common to the two countries are listed. If there are no common requirements, this heading is not used.

NORWAY:

Here the requirements that are specific to Norway are listed.

SWEDEN:

Here the requirements that are specific to Sweden are listed. The “Sweden only”-section goes on until the next level two, level three, or level four heading, whichever is first.

2.2.6 Accuracy

If a requirement is quantitative, i.e. there is a numerical limit; the accuracy of the limit is given by the number of digits used for the requirement.

2.3 Abbreviations and Definitions

2.3.1 Abbreviations

ABAB	Operation sequence (see 4.4.4)
ABS	Absolute value
AC	Alternating current
A/D	Analog to digital conversion
ARO	Operation sequence (see 4.4.4)
AT	Autotransformer
ATC	Automatic train control (called ATP in most countries)
ATP	Automatic train protection (called ATC in the Nordic countries)
BP	Band-pass
BT	Booster transformer
BW	Butterworth
bw	Bandwidth
DAT	Digital audio tape
DC	Direct current
EMC	Electromagnetic compatibility
EMI	Electromagnetic interference
f_c	Centre frequency
FFT	Fast fourier transform
FTGS	Type of track circuit
GPS	Global positioning system
ID	(Data recording) identity
IIR	Infinite impulse response
I_N	Rated current
LOOP	Operation sequence (see 3.3.4)
N	Norway
N/A	Not applicable
OHL	Overhead (contact) line
P1-P17	Compatibility requirements, power supply systems

PWM	Pulse width modulation
RMS	Root-mean-square
RSS	Root-sum-square
S	Sweden
S1-S9	Compatibility requirements, signalling and telecommunication systems
T1-T7	Test categories
TBD	To be defined
THD	Total harmonic distortion
TI 21	Type of track circuit

2.3.2 Definitions

Bandwidth	In accordance with EN 50 238
Bin	Output from a FFT. For example, a FFT with a 1 s window length produces bins at the frequencies 0 Hz (DC), 1 Hz, 2 Hz, . . .
Closed track	A line section that is single-end fed, and where no other rail vehicles are activated or in operation
Crest voltage	The highest value within one period of the rectified AC voltage. For an ideal sinusoidal voltage, the crest value equals $\sqrt{2}$ times the RMS value.
Fault mode	Degraded vehicle operation mode with one or more subsystems (converter, filter, or similar) cut-out
Hanning	Weight function used in combination with the FFT, in order to reduce the effect of transients
Normal operation	Vehicle operation mode with all subsystems in intended operation
Quasi-stationary	An operation condition where the variables (e.g., RMS voltage or current) vary so slowly that no oscillations or other dynamic effects are triggered
Rated current	The line current drawn by the vehicle when operating at full power at the nominal voltage of 15.0 kV
RMS	Root-Mean-Square. Please notice that different window lengths are used for different purposes. Generally, the window length is defined as a part of each specific requirement
Spectral leakage	The phenomenon that a FFT bin at a certain frequency is “contaminated” with energy originating from signal components at the frequencies of the neighbouring bins. This is an effect of the Hanning window
Window	Time duration over which data is analysed, e.g., 60 ms or 1 s

2.4 Scope

NORWAY AND SWEDEN:

This document is foremost intended for manufacturers or operators who plan:

- A) to specify and design new vehicles for operation in Norway and/or Sweden,
- B) to modify or rebuild already existing vehicles, or
- C) to introduce already existing vehicles that have not previously been operating in Norway or Sweden.

For this purpose, the document provides detailed information about the infrastructure in the two countries. Some of this information is found in connection with the various requirements, but most is given in the attached appendices.

NORWAY:

The validity and the application of the requirements in this document are defined in the JD 590 “Characteristics of the infrastructure” chapter 1 section 1.4.2. The document JD 590 is an overall document that describes the infrastructure and the compatibility requirements in Norway for all relevant fields. This present document concerning electric compatibility is hence a part of JD 590 as:

- Signal interference is treated in JD 590 chapter 5 “Signalling and train control systems”
- Telecommunication is treated in JD 590 chapter 6 “Telematic applications”
- Power supply is treated in JD 590 chapter 4 “Energy”

SWEDEN:

The requirements in this document are valid for:

- First time use of rolling stock or reintroduction of rolling stock that have been considered out of use permanently.
- Rolling stock that is going to be introduced on sections of track not included in current acceptance.
- Changes, both in hardware and software, in rolling stock usage not in compliance with current acceptance.
- Modifications of rolling stock in a way that may affect the compliance with the current acceptance.

This means that the requirements in this document are valid for new electrical traction vehicle and old used vehicles that have not been used in normal operation in Norway or Sweden before. An old vehicle used in Norway is not automatically accepted in Sweden.

The requirements in this document can however be discussed when applied on imported old vehicles, except for the Electrical Safety and requirements regarding signalling circuits and psophometric currents. Requirements regarding signalling circuits are always valid due to safety aspects. Requirements regarding psophometric currents are valid due to effects for third party.

A summary of how and for which rolling stock the requirements are valid is given in the table below:

Category of rolling stock	Age of the rolling stock	
	Vehicle design started after 2007-01-01	Vehicles designed before 2007-01-01
Vehicles specifically designed for use in Sweden only	All requirements are mandatory.	<p>Already accepted, but any rebuilds or modifications should aim for improving compatibility, and must not reduce compatibility.</p> <p>For already accepted vehicles, which are to be put in operation on new lines for which the acceptance is not valid, relevant requirements are valid in order to maintain traffic and not to disturb the electrical infrastructure. Relevant requirements are decided on a case-to-case basis.</p>
Vehicles designed for cross border operation, or for use also in other countries	<p>Safety requirements and requirements regarding signalling systems and telecommunications are mandatory.</p> <p>Non-compatibilities with other requirements might be accepted on a case-to-case basis, but only if it can be demonstrated that the requirements are in fundamental conflict with technical requirements from other countries of operation.</p>	<p>Safety requirements and requirements regarding signalling systems and telecommunications are mandatory.</p> <p>Non-compatibilities with other requirements might be accepted on a case-to-case basis, but only if it can be demonstrated that a rebuild would be in fundamental conflict with technical requirements from other countries of operation, or if it can be demonstrated that the cost of a rebuild is out of proportion.</p>
Vehicles originally designed for use in other countries, but imported for future use solely in Sweden	<p>Safety requirements and requirements regarding signalling systems and telecommunications are mandatory.</p> <p>Non-compatibilities with other requirements might be accepted on a case-to-case basis, but only if it can be demonstrated that the cost of a rebuild is out of proportion.</p>	<p>Safety requirements and requirements regarding signalling systems and telecommunications are mandatory.</p> <p>Non-compatibilities with other requirements might be accepted on a case-to-case basis, but only if it can be demonstrated that the cost of a rebuild is out of proportion.</p>

Table 1. Use of the requirements (Sweden only).

2.5 General information about the infrastructure

This chapter gives a short introduction to traction power supply systems and track signalling circuits in Norway and Sweden. More specific data about the infrastructure is given as information in APPENDIX 1: Infrastructure data and related information.

2.5.1 General

In Norway and Sweden the earth resistivity is high in comparison to most of the rest of Europe. This has direct an effect on traction power supply design to avoid disturbing other electrical systems.

2.5.2 Norway

In Norway there are 2500 km of electrified railway (2004). The network around the capital Oslo is meshed with both double and single-track lines. Around this centre there are long (> 500 km) single-track lines to other parts of the country. The Norwegian single-phase network is much weaker than in rest of Europe. In some areas the overhead contact line impedance is so large that changes in the power demand from one train may cause voltage variations up to some kilovolts. Both tap changer vehicles, phase controlled vehicles and inverter vehicles with and without filters operate in the network.

The power supply system is of the type 15 kV, 16.7 Hz. It is synchronized with the 50 Hz national grid, i.e. a decentralized system. There is however a small centralized system in the Oslo area consisting of a 55 kV, 16 2/3 Hz single-phase high voltage transmission line fed by one small hydro power station. This system is connected to the contact lines system via 5 substations (which can be located together with rotary converters).

Apart from the small centralized system the power is fed into the traction power supply system by rotary and static (power electronic) converter stations, which convert the energy from 50 Hz, three-phase, to 16 2/3 Hz, single-phase. The number of active converter units in each converter station is adapted to the hourly variation in load demand to allow maintenance and reduce the losses. There is one small hydro power station feeding directly to the overhead contact line system. In normal operation there is often a one-to-one relation between one converter station capacity and load demand from one train. Due to this, low frequency oscillations have often caused severe problems when new vehicles have been introduced.

In normal operation the system is interconnected between the feeding points, but in order to maintain both rail tracks and contact line, sectioning of the system is a common operation mode.

At present, the booster transformer (BT) system, with or without return conductors, is the main feeding system for contact lines in Norway. However, Jernbaneverket plans to build autotransformer (AT) systems for main long distances lines. There are also some series capacitances and one shunt capacitor in the single-phase network in order to reduce inductive contact line impedance, strengthening the voltage and feeding reactive power. The return path for the traction current, regardless of system and apart from return conductors or any extra earth conductors, always comprise both rails, with exception of stations where single rail track signalling circuits occurs.

On electrified lines AC track signalling circuits are used, either double rail or jointless. Most common are 95 and 105 Hz uncoded track signalling circuits.

ATC equipment type EBICAB 700 is used on most lines.

2.5.3 Sweden

In Sweden there are 9 543 km of electrified railway (2004). The railway network is meshed except for the northern part of Sweden. Most of the lines are single track lines except for lines close to Stockholm and the lines between the cities Stockholm, Gothenburg and Malmö.

The power supply system is of the type 15 kV, 16.7 Hz. The system is decentralized and synchronized with the 50 Hz national grid. The power is fed into the traction power supply system by converter stations, which convert the energy from 50 Hz, three-phase, to 16 2/3 Hz, single-phase. The converters are of both rotary and static (power electronic) type. The number of active converter units in each converter station is adapted to the load.

In order to reduce the number of converter stations, the contact overhead line system is also fed by a 132 kV system (a two-phase 2 x 66 kV system with directly earthed midpoint) with transformer substations. This system is used from the middle to the northern parts of Sweden. There is no power generation connected directly to the 132 kV system. The system is fed from transformers connected to the 15 kV 16,7 Hz busbars at the converter stations.

The two feeding systems for contact lines in Sweden are; BT-system (booster-transformer system) with one or two return conductors and AT-system (auto-transformer system). Sometimes also a strengthening wire (reinforcement wire, booster wire) occurs. This is more common in the northern part of Sweden, and this type of reinforcement wire is always used on AT-systems. Its objective is to lower the impedance. Sometimes an additional earth wire is used. This type of earth wire is planned to become standard on AT-system lines. A combined AT/BT-system is currently under investigation for introduction (a first small installation is made).

Most of the railway lines are fed from both ends (double sided feeding). Due to the high earth resistivity booster transformer systems with return conductors are mainly used, when not autotransformer systems are implemented, due to EMC requirements. This causes normally higher line impedance than in the central and south of Europe, where the return current can use the rails and earth all the way to the feeding point. The system is relatively weak with rather high voltage drops.

Only DC track signalling circuits exist on electrified lines in Sweden. At some non-electrified low traffic lines, radio block systems are used.

Only one of the rails, the S-rail, is used for the return path of the traction current. This is regardless of what type of feeding system that is being used (BT- or AT-system). The other rail is always isolated, I-rail, and is used for the DC track signalling circuits.

ATC equipment type EBICAB 700 is used on most lines.

2.6 Revision history

- 05-01-2007: First version, based on the NIM NES-R10 report with the same title as this document, from 27.11.2006.
- 07-01-2009: Second version

3 SIGNALLING SYSTEMS AND TELECOMMUNICATION

3.1 References

3.1.1 Normative references

No.	Standard	Applicable to	
		Signalling	Power
1.1	EN 50 110-1: Operation of electrical installations. CENELEC, European Standard.		X
1.2	EN 50 121: Railway applications – Electromagnetic compatibility (relevant parts in this context). Part 1: General Part 2: Emission of the whole system to the outside world Part 3-1: Rolling stock – Train and complete vehicle Part 3-2: Rolling stock – Apparatus Part 4: Emission and immunity of the signalling and telecommunication apparatus Part 5: Emission and immunity of fixed power supply installations and apparatus CENELEC, European Standard.	X	X
1.3	EN 50 122-1 Railway applications- Fixed installations Part 1: Protective provisions relating to electrical safety and earthing. CENELEC, European Standard.		X
1.4	EN 50 128: Railway applications – Communications, signalling and processing systems – Software for control and protection systems. CENELEC, European Standard.	X	
1.5	EN 50 153: Railway applications – Protective provisions relating to electrical hazards. CENELEC, European Standard.		X
1.6	EN 50 155: Railway applications Electronic equipment used on rolling stock. CENELEC, European Standard.	X	
1.7	EN 50 163: Railway applications – Supply voltages of traction systems. CENELEC, European Standard.		X
1.8	EN 50 207: Railway applications – Electronic power converters for rolling stock. CENELEC, European Standard.		X
1.9	EN 50 215: Railway applications – Test of rolling stock after completion of construction and before entry into service. CENELEC, European Standard.	X	X
1.10	EN 50 238: Railway applications – Compatibility between rolling stock and train detection systems. CENELEC, European Standard.	X	
1.11	EN 50 388: Railway applications – Power supply and rolling stock – Technical criteria for the coordination between power supply (substation) and rolling stock to achieve interoperability. CENELEC, European Standard.		X

1.12	UIC 550, 550-1, 550-2, 550-3: Power supply installations for passenger stock.		X
1.13	UIC 552: Electrical power supply for trains – Standard technical characteristics of the train line.		X
1.14	UIC 554-1: Power supply to electrical equipment on stationary vehicles from local mains system or another source of energy at 220 V or 380 V, 50 Hz.	X	
1.15	UIC 512: Conditions to be fulfilled in order to avoid difficulties in the operation of track circuits and treadles.	X	
1.16	BVS 545.43501: Requirements on external antennas for railway vehicles (only published in Swedish: ”Krav på yttre antenner för järnvägsfordon”) . Banverket. Only normative for Sweden.	X	
1.17	ITU-T Recommendation O.41: Psophometer for use on telephone-type circuits.	X	

3.1.2 Other references

No.	Standard	Applicable to	
		Signalling	Power
2.1	HS TSI: Directive 96/48/EC – Interoperability of the trans-European high speed rail system, 96/48 ST14EN03 ENE part 2, Draft from 22.06.2006.	X	X
2.2	Characteristics of infrastructure. Document JD 590. Jernbaneverket, 01.02.2005.	X	X
2.3	Electro-technical requirements on new electrical vehicles regarding compatibility with the power supply system and other electrical vehicles, BKE 00/14, rev. H. Banverket, July 2004.	X	X
2.4	Rotating converters BV/JBV: Description of simulation model. emkamatik document 06-0132, ver. 1. Stefan Menth, emkamatik, 18.9.2006.		X
2.5	EN 61000-4-7, March 1993. Electromagnetic compatibility (EMC). Part 4: Testing and measurement techniques. Section 7: General guide on harmonics and interharmonics measurements and instrumentation, for power supply systems and equipment connected thereto. IEC, CENELEC.		X

3.2 Compatibility Requirements

NOTE:

The limits and requirements in this chapter are under investigation and shall be treated accordingly. Please notice that operating experience indicates that lower limits may be required in some frequency ranges on certain line sections in Norway. These requirements are under consideration. Jernbaneverket may on some route sections permit slightly excessive interference currents for some frequencies. Based on documentation for the noise current spectrum of the vehicle, Jernbaneverket will decide whether or not it is compatible with the route sections in question.

3.2.1 S1: DC track circuits

3.2.1.1 Information

NORWAY:

DC track signalling circuits are used only at non-electrified railway stations, plus one single electrified railway station.

SWEDEN:

DC track circuits are the only train detection system in use on electrified lines in Sweden.

Only two credible mechanisms have been identified by which an electric vehicle is capable of generating excessive DC interference currents:

1. Transformer inrush. Low levels can be achieved by a proper design of the main transformer.
2. Ice on the overhead contact wire. It is recognised that it may not be feasible to design a rail vehicle in such a way that compliance can be guaranteed at all ice conditions.

A third cause can be faults in the vehicle.

3.2.1.2 Requirements

General requirements for the vehicle and the signalling equipment are in accordance with EN 50 121-3-1 and EN 50 121-4.

NORWAY:

No requirements.

SWEDEN:

Interference limits, normal operation.

The following interference limits apply, with the exception of the inrush current of the main transformer:

Frequency band	Bandwidth (low-pass)	RMS time	Limit value
0.0 - 2.0 Hz	-3.0 dB: 2.0 Hz	N/A	25.0 A

These limits are applicable for one vehicle, and for the maximum configuration of vehicles (i.e. multiple units) for which the approval must be valid.

Interference limits, transformer inrush.

The DC-component of the inrush current of the main transformer/s, must not exceed 45.0 A for more than 1.50 seconds, and also not exceed 25.0 A for more than 2.50 seconds. The DC-component is here defined as the mean value over one period of the fundamental, moving average calculation.

This is applicable for one vehicle, and for the maximum configuration of vehicles (i.e. multiple units) for which the approval must be valid. In a multiple formation, it is suggested that the cut-in of the main circuit breakers is staggered, e.g., with a 5 s delay between each cut-in event.

3.2.1.3 Verification

NORWAY:

N/A.

SWEDEN:

Normal operation test

Verification shall be done by test runs with measurement and data recording equipment being installed in the vehicle, at normal weather conditions (no frosty lines), and in accordance with the test specification section 3.3. The current transducer must handle the frequencies from DC and upwards.

The following signal processing of the recorded line current signal is suggested:

Signal processing	Limit value
(Downsampling to 1 kHz, followed by) 2.0 Hz 4 th order Butterworth low-pass filter, followed by an ideal rectifier to give the absolute value.	25.0 A

Inrush current test

The tests shall be performed at a location where the short circuit current is greater than or equal to 20 kA, i.e. $I_k \geq 20$ kA on a single-track line. The train shall be placed beyond the first booster transformer, counting from a converter station, as described in section 3.3.4. (NOTE: this is not the same situation as for the AC inrush current tests, see chapter 4.4.4. The test specified here implies the test location to be at Ockelbo converter station with all converters in operation and all other converter stations connected to the 132 kV system. Other tests sites with scaling of the limit are under investigation.)

The following signal processing of the recorded line current signal is suggested:

Signal processing	Limit value
(Downsampling to 1 kHz, followed by) 60 ms moving average, followed by an ideal rectifier to give the absolute value, followed by an assessment of the time duration for the level exceeding the following values:	
45.0 A:	1.50 s
25.0 A:	2.50 s

3.2.1.4 Documentation

NORWAY:

N/A

SWEDEN:

Documentation shall be a conformity statement and documentation of performed tests.

3.2.2 S2: 95 Hz and 105 Hz track circuits (Norway only)

3.2.2.1 Information

Track circuits operating at 95 Hz and 105 Hz are the most commonly used in Norway. Impedance bonds for 95/105 Hz may be used to allow return current to pass by insulated joints used for separating track circuits.

3.2.2.2 Requirements

General requirements for the vehicle and the signalling equipment are in accordance with EN 50 121-3-1 and EN 50 121-4.

Interference limits.

The following interference limits apply:

Centre frequencies f_C	Bandwidth	Time limit	Limit value
95.0 Hz	- 3.0 dB: $f_C \pm 3.0$ Hz	1.00 s	1.00 A
105.0 Hz			

The 1.00 A current limit may be exceeded for shorter time periods than 1.00 s. These limits are applicable for one vehicle, and for the maximum configuration of vehicles (i.e. multiple units) for which the approval must be valid.

Requirements for monitoring.

The vehicles must be equipped with interference monitoring systems for the 95 Hz and 105 Hz line current components. The monitoring system must automatically open the main circuit breaker within 2.0 s if the 2.00 A trip level is exceeded.

The suggested signal processing for the monitor is FFT with 1.00 Hz resolution (1.00 s window length). The trip level is 2.00 A RMS for any bin in the bands 92-98 Hz and 102-108 Hz.

3.2.2.3 Verification

Verification shall be done by test runs with measurement and data recording equipment being installed in the vehicle, in accordance with the test specification section 3.3.

The following signal processing of the recorded data is suggested:

Centre frequencies f_C	Signal processing	Limit value
95 Hz and 105 Hz	(Downsampling to 1 kHz, followed by) 2·3 rd order Butterworth band-pass filters with -3.0 dB points at each $f_C \pm 3.0$ Hz, followed by moving RMS, time window < 1.00 s	1.00 A

3.2.2.4 Documentation

Documentation shall be a conformity statement and documentation of performed tests.

3.2.3 S3: TI 21 track circuits (Norway only)

3.2.3.1 Information

TI 21 track circuits are used on some new lines in Norway, e.g., the Vestfold line.

TI 21 track circuits are designed with 8 channels A-H. The frequency of the carrier signal for the track circuit shifts between two values in each channel. The modulation rate of the frequency shift must lie within certain limits for a correct operation of the track circuit.

3.2.3.2 Requirements

General requirements for the vehicle and the signalling equipment are in accordance with EN 50 121-3-1 and EN 50 121-4.

The following interference limits apply:

Centre frequencies f_C	Bandwidth <i>See note 1</i>	Time limit	Limit value
Channel A: 1682 Hz and 1716 Hz	-3.0 dB: $f_C \pm 6.0$ Hz -20 dB: $f_C \pm 30$ Hz	1.50 s	250 mA
Channel B: 2279 Hz and 2313 Hz			
Channel C: 1979 Hz and 2013 Hz			
Channel D: 2576 Hz and 2610 Hz			
Channel E: 1532 Hz and 1566 Hz			
Channel F: 2129 Hz and 2163 Hz			
Channel G: 1831 Hz and 1865 Hz			
Channel H: 2428 Hz and 2462 Hz			

The current limit may be exceeded for shorter time periods than 1.50 s. These limits are applicable for one vehicle, and for the maximum configuration of vehicles (i.e. multiple units) for which the approval must be valid.

3.2.3.3 Verification

Verification shall be done by test runs with measurement and data recording equipment being installed in the vehicle, in accordance with the test specification section 3.3.

The following signal processing of the recorded data is suggested:

Centre frequencies f_C	Signal processing	Limit value
1682 Hz and 1716 Hz 2279 Hz and 2313 Hz 1979 Hz and 2013 Hz 2576 Hz and 2610 Hz 1532 Hz and 1566 Hz 2129 Hz and 2163 Hz 1831 Hz and 1865 Hz 2428 Hz and 2462 Hz	Band pass filters with a rejection of ≤ 3.0 dB at ± 6.0 Hz from each f_C , and ≤ 20 dB at ± 30 Hz from each f_C , followed by moving RMS, time window < 1.50 s. <i>See note 2.</i>	<i>TBD</i>

Note 2: Much work has been spent in the UK in order to design digital filters with the best possible match to these limits, and many proposals exist. It is suggested that the design of filters is left to the applicants. It is likely however that the -20 dB figure could actually be somewhat more – final value is under investigation. (TDB = To Be Determined).

3.2.3.4 Documentation

Documentation shall be a conformity statement and documentation of performed tests.

3.2.4 S4: FTGS track circuits (Norway only)

3.2.4.1 Information

The jointless FTGS track circuits operate at 4 frequencies in the 4.5 to 6.5 kHz frequency band (FTGS46), and at 8 frequencies in the 9 to 17 kHz band (FTGS917). They are used on some newer lines in Norway, e.g., the Gardermoen line.

3.2.4.2 Requirements

General requirements for the vehicle and the signalling equipment are in accordance with EN 50 121-3-1 and EN 50 121-4.

The following interference limits apply:

FTGS46

Centre frequencies f_C	Bandwidth (<i>see note 3</i>)	Time limit	Limit value
4.75 kHz	-3.0 dB: $f_C \pm 200/2$ Hz	40 ms	1.00 A
5.25 kHz	-3.0 dB: $f_C \pm 206/2$ Hz		
5.75 kHz	-3.0 dB: $f_C \pm 214/2$ Hz		
6.25 kHz	-3.0 dB: $f_C \pm 220/2$ Hz		

Note 3: Attenuation at adjacent channels: max. 30 dB.

FTGS917

Centre frequencies f_C	Bandwidth (see note 4)	Time limit	Limit value
9.5 kHz	-3.0 dB: $f_C \pm 360/2$ Hz	40 ms	0.50 A
10.5 kHz	-3.0 dB: $f_C \pm 380/2$ Hz		
11.5 kHz	-3.0 dB: $f_C \pm 400/2$ Hz		
12.5 kHz	-3.0 dB: $f_C \pm 425/2$ Hz		
13.5 kHz	-3.0 dB: $f_C \pm 445/2$ Hz		
14.5 kHz	-3.0 dB: $f_C \pm 470/2$ Hz		
15.5 kHz	-3.0 dB: $f_C \pm 490/2$ Hz		
16.5 kHz	-3.0 dB: $f_C \pm 510/2$ Hz		

Note 4: Attenuation at adjacent channels: max. 30 dB.

The current limits may be exceeded for shorter time periods than 40 ms.

3.2.4.3 Verification

Verification shall be done by test runs with measurement and data recording equipment being installed in the vehicle, in accordance with the test specification section 3.3.

The following signal processing of the recorded data is suggested:

FTGS46

Centre frequencies f_C	Bandwidth bw	Signal processing	Limit value
4.75 kHz	200 Hz	2·2 nd order Butterworth band pass filters, -3 dB at each $f_C \pm bw/2$ Hz, followed by moving RMS, time window < 40 ms	1.00 A
5.25 kHz	206 Hz		
5.75 kHz	214 Hz		
6.25 kHz	220 Hz		

FTGS917

Centre frequencies f_C	Bandwidth bw	Signal processing	Limit value
9.5 kHz	360 Hz	2·2 nd order Butterworth band pass filters, -3 dB at each $f_C \pm bw/2$ Hz, followed by moving RMS, time window < 40 ms	0.50 A
10.5 kHz	380 Hz		
11.5 kHz	400 Hz		
12.5 kHz	425 Hz		
13.5 kHz	445 Hz		
14.5 kHz	470 Hz		
15.5 kHz	490 Hz		
16.5 kHz	510 Hz		

3.2.4.4 Documentation

Documentation shall be a conformity statement and documentation of performed tests.

3.2.5 S5: Telecommunication disturbances and psophometric currents

3.2.5.1 Information

Interference with digital systems such as PCM, ISDN, etc is not yet covered in this document. This is a field for which more work will be done. Information regarding GSM-R can be found in EIRENE standards from UIC.

The harmonics in the traction current of a railway system may induce noise in conventional analogue telecommunication system. The acceptable level of noise on conventional analogue telephone lines is specified by ITU-T. The limits in this document refer to the psophometric weighted traction current defined as:

$$I_{pe} = \frac{1}{P_{800}} \sqrt{\sum_{n=1}^{\infty} (h_f \times P_{fn} \times I_n)}$$

where $h_f=1$, which is the equivalent psophometric current measured or calculated for interaction with a telephone line as a cable. P_{fn} is in accordance with ITU-T. For values of P_{fn} see Appendix 9.

3.2.5.2 Requirements

The psophometric weighted traction current must not exceed 1.50 A. The value refers to the 99%- percentile of the measured psophometric current, i.e., the level must be below 1.50 A for 99% of the operation time.

The requirement is applicable for one vehicle and for the maximum configuration of vehicles (i.e. multiple units) for which the approval must be valid.

In case of a fault on the vehicle, for instance when one or more of the traction modules or filters is/are disconnected and the increase of the psophometric current is less than 6.0 dB, the vehicle is allowed to be in working condition until it reaches a workshop, for up to 24 hours. For such a case the limit is doubled. If this demand can not be fulfilled, the vehicle shall be transported in a non-working condition.

3.2.5.3 Verification

Verification shall be done by test runs with measurement and data recording equipment being installed in the vehicle, in accordance with the test specification section 3.3.

For each LOOP operation cycle, the 99%-percentile of the psophometric current level shall be determined. See also EN 50 121-3-1, Annex A (informative). The tolerance of the

psophometric weight characteristics, as well as the dynamic characteristics, shall comply with ITU-T O.41.

The following signal processing of the recorded data is suggested:

Signal processing	Limit value
IIR band-pass filter with a characteristic as defined in Appendix 9, followed by a moving RMS with a time window of 140 ms, followed by an analysis of the levels over time (e.g., by determining the percentage cumulative distribution), followed by an assessment of the 99%-percentile level.	1.50 A

3.2.5.4 Documentation

Documentation shall be a conformity statement and documentation of performed tests in a technical report. The report shall for each test lap state the 99%-percentile, and the summary shall state the variation of the 99%-percentiles (minimum, typical, and maximum values) for each operation mode (normal operation, and all relevant fault modes).

If the psophometric current varies significantly with speed (e.g., in the case of a rectifier vehicle), the report must additionally present a plot of the psophometric current versus speed.

3.2.6 S6: Broad-band interference (Norway only)

3.2.6.1 Information

Historically, the Norwegian State Railways applied broad-band interference limits rather than limits specifically at the signalling frequencies. Jernbaneverket has now initiated an investigation whether or not these broad-band limits are still technically justified; however, until this investigation is finalized, the limits remain valid.

3.2.6.2 Requirements

The following interference limits apply:

Frequency band	Time limit	Limit value
TBD – 7 kHz <i>See note 5</i>	1.00 s	1.00 A RMS
7 – 9 kHz		0.50 A RMS
> 9 kHz		0.33 A RMS

Note 5: The lower frequency limit is currently under investigation and is to be decided (=TBD).

The current limits may be exceeded for shorter time periods than 1.00 s.

3.2.6.3 Verification

Verification shall be done by test runs with measurement and data recording equipment being installed in the vehicle, in accordance with the test specification section 3.3.

The following signal processing of the recorded data is suggested:

Frequency band	Signal processing	Time limit	Limit value
TDB – 7 kHz <i>See note 6</i>	FFT with 8 1/3 Hz resolution (120 ms time window) followed by < 1.00 s moving RMS along the time axis of each FFT bin. The limit value applies per FFT bin.	1.00 s	1.00 A RMS
7 – 9 kHz			0.50 A RMS
> 9 kHz			0.33 A RMS

Note6: The lower frequency limit is currently under investigation and is to be decided (=TBD).

3.2.6.4 Documentation

Documentation shall be a conformity statement and documentation of performed tests.

3.2.7 S7: Radiated interference

3.2.7.1 Information

Conformance with EN 50 121 is the basis for new constructions and upgrading of infrastructure systems.

3.2.7.2 Requirements

Requirements are in accordance with EN 50 121-2 and EN 50 121-3-1. Deviations, based on further evaluation, may be acceptable on a case-to-case basis.

3.2.7.3 Verification

Verification shall be performed by tests in accordance with EN 50 121-2 and EN 50 121-3-1.

3.2.7.4 Documentation

Documentation shall be a conformity statement and documentation of performed tests.

3.2.8 S8: Outside antennas on vehicles

3.2.8.1 Information

NORWAY AND SWEDEN:

Requirements in this document consider outside antennas for railway vehicles.

3.2.8.2 Requirements

NORWAY AND SWEDEN:

Antennas for railway vehicles shall satisfy the requirements on touch voltage in accordance with EN 50 122-1 *Railway applications- Fixed installations Part 1: Protective provisions relating to electrical safety and earthing*, and EN 50 155 *Railway applications Electronic equipment used on rolling stock*.

SWEDEN:

Antennas for railway vehicles shall satisfy the requirements in Banverket's document BVS 545.43501 *Krav på yttre antenner för järnvägsfordon*. (Requirements on external antennas for railway vehicles).

3.2.8.3 Verification

NORWAY:

According to relevant standards, EN 50 122-1 and EN 50 155.

SWEDEN:

According to BVS 545.43501 *Requirements on external antennas for railway vehicles*. Clause 4.1- 4.6. The tests should be performed as a factory type test.

3.2.8.4 Documentation

NORWAY AND SWEDEN:

A conformity statement.

3.2.9 S9: Resistance between wheelsets

3.2.9.1 Information

N/A.

3.2.9.2 Requirements

The resistance between wheels of a wheel set must be according to UIC512:1979 ($< 0.1 \Omega$).

3.2.9.3 Verification

According to UIC512:1979.

3.2.9.4 Documentation

A conformity statement.

3.3 Validation and tests

3.3.1 Requirements prior to tests

NORWAY AND SWEDEN:

Before test runs and/or demonstrations are allowed on the railway lines in Norway or Sweden, certain documentation is required. In addition to the documentation mentioned later in this chapter, which refers to electrical requirements and how to perform tests, there are some other pre-requirements to be met. These pre-requirements and documentation concern topics like:

- train control (ATC)
- profile
- running dynamics
- axle loads
- current collector
- etc.

These pre-requirements are not covered in this document and it is the responsibility of the applicant for the acceptance to contact Jernbaneverket and/or Banverket to get the complete information regarding these requirements.

(Note: it is possible to test or demonstrate a vehicle without ATC by connecting the vehicle under test to an already accepted vehicle. Special provisions must however be made so that correct test conditions are met, i.e. the accepted extra vehicle must not influence the test results.)

NORWAY:

The requirements regarding other topics than electric compatibility captured in this document is to be clarified as a part of the overall compatibility process which is described in JD 590 chapter 1.

3.3.1.1 Interference currents

Documentation which contains estimations, calculations, or previous measurements of interference currents according to the requirements S1-S6 is required. If such documentation cannot be made available, a preliminary test must be performed on a closed track before any other tests are performed. See also the requirements in section 3.2.1 to 3.2.6.

3.3.1.2 Radiated EMI (S7, part of T6)

EMC test regarding radiated emission shall be performed by the manufacturer (or applicant) at the factory before any tests on railway lines in Norway or Sweden. See section 3.2.7.

3.3.1.3 Simulations of dynamic vehicle behaviour

Testing of new vehicles on the railway infrastructure is very costly and shall be kept to a minimum for the benefit of all involved parties in long term. In order to reduce the risk of a

failure of some tests as well as to document vehicle characteristics which can not be tested directly, simulations shall be performed by the vehicle manufacturer.

It is recommended that the simulation results are presented to and discussed with Jernbaneverket and/or Banverket prior to the first tests with the new vehicle.

This concerns low frequency power oscillations (see 4.3.8) and electrical resonance stability (see 4.3.9) and is based on EN 50388:2005, clause 10, steps 1 to 11 of the compatibility study.

3.3.1.4 Current or power control at low voltage

Documentation of current limitation as function of voltage is required.

3.3.1.5 Regenerative braking

Documentation of the voltage limitation functions when using regenerative brake is required.

3.3.1.6 Test plan

A test plan shall be presented to Jernbaneverket and/or Banverket before any measurements or tests are carried out. The test plan shall contain a description on how the tests are performed (i.e. what lines shall be used, closed track or mixed traffic and so on) and on the vehicle constellation (load, weight and so on). Furthermore, the test plan shall include a description of the instrumentation and measurement methods that will be used, and how the instrumentation is calibrated. This information shall also be included in the test reports.

3.3.2 Coordination with tests regarding compatibility with the power supply

The tests specified in the following sections can to a wide extent be coordinated with the tests regarding compatibility with the power supply.

3.3.3 General test program

Table 2 below defines the test categories T1-T7, and outlines the minimum number of tests specifically addressing the requirements S1-S6.

Cat.	Condition	Scope and train operation
T1	Closed track, rotating converters	2 LOOP sequences in normal operation, and 1 LOOP sequence in each fault mode. (Plus additional tests for P-requirements; the data from these tests must be analyzed also for the S-requirements S1-S6).
T2	Closed track, static converters	2 LOOP sequences in normal operation, and 1 LOOP sequence in each fault mode, altogether in each end of the line (close to and far away from the substation. I.e., a total of 4 LOOP sequences in normal operation, and 2 LOOP sequence in each fault mode. (Plus additional tests for P-requirements; the data from these tests must be analyzed also for the S-requirements S1-S6).
T3	Mixed traffic	Mainly tests for P-requirements, but the data from these tests must be analyzed also for the S-requirements S1-S6
T4	Transformer inrush (peak AC)	N/A (P-requirement only)
T5	Transformer inrush (DC, S only)	Minimum 25 successful inrush events
T6	Other tests	According to EN 50 121-3
T7	Non-test approval	N/A

Table 2. General test requirements, S-requirements.

The tests of category T1 and T2 can be performed in either country. The tests T3 must be performed in the country/countries where the vehicle is going to operate. Test T5 must be performed in Sweden. Test T6 can be performed anywhere with 15 kV 16.7 Hz supply.

3.3.4 Test details

3.3.4.1 Test sites

The following test sites are suggested:

Cat.	Norway	Sweden
T1	Hønefoss-Nesbyen on the Bergen line.	Gemla-Lessebo, Alvesta-Kalmar line.
T2	Lillestrøm-Gardermoen, Gardermoen Airport line.	Eskilstuna-Nykvarn, Eskilstuna-Södertälje line.
T3	Oslo area.	Borlänge area (Borlänge-Krylbo, Borlänge-Ludvika).
T4	N/A (P-requirement only).	
T5	N/A	Ockelbo.
T6	Vehicle suppliers own test tracks.	
T7	N/A	

Table 3. Test sites, S-requirements.

3.3.4.2 Power supply configurations

CATEGORY T1: CLOSED TRACK, ROTATING CONVERTERS

The test line must be single-end supplied from one or two rotating converters in island operation. There must be no other trains activated or in operation on the test line. It is recommended that the test permissions allow for operation without ATC.

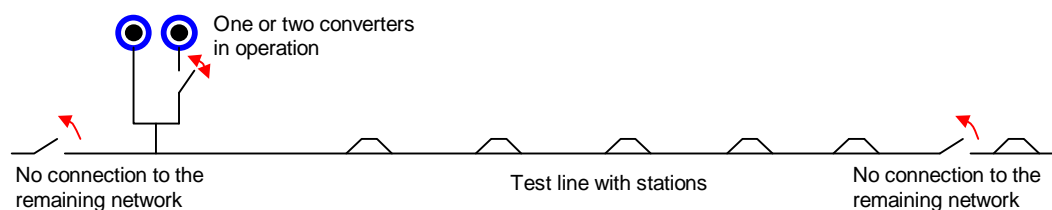

Figure 1. Supply conditions for T1 tests, S-requirements.

CATEGORY T2: CLOSED TRACK, STATIC CONVERTERS

The test line must be single-end supplied from one or two static converters. Since these converters are not designed for island operation, the remaining network must be connected in the supply end. There must be no other trains activated or in operation on the test line. It is recommended that the test permissions allow for operation without ATC.

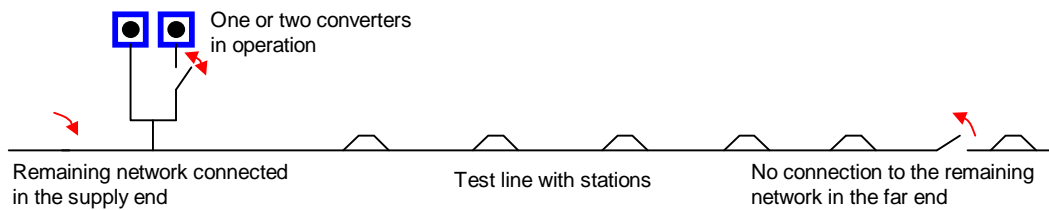

Figure 2. Supply conditions for T2 tests, S-requirements.

CATEGORY T3: MIXED TRAFFIC

No specific requirements.

CATEGORY T5: TRANSFORMER INRUSH

Please refer to the detailed description of these tests in chapter 3.3.4.6 below.

3.3.4.3 Train configuration

All tests shall be performed with one vehicle alone and with all configurations of vehicles (i.e. multiple units) for which the approval must be valid. The tests must cover both normal fault-free operation, i.e., with all converters running and all filters etc. in normal mode, as well as all degraded operation modes, i.e., with one or more converter(s) and other subsystems cut-out.

3.3.4.4 Train load

Locomotives must be loaded by a reasonably heavy train ($\approx 1\text{-}2$ t per kN max. tractive effort, or $\approx 50\text{-}100$ t per MW max. power, whichever is the greater) during all tests T1 and T3. During tests T2, a somewhat lighter load may be used (some 25% of the values above).

3.3.4.5 Train operation – LOOP sequence

The train must be operated according to the “LOOP” speed profile shown in figure 3 below, during all tests specifically addressing the S-requirements.

All vehicles must perform tests up to their speed limit during test category T2. During the test categories T1 and T3, the maximum speed is typically given by the speed limit of the line (or, in the case of locomotives, by the load wagons), meaning that the LOOP sequence must be terminated at a lower speed.

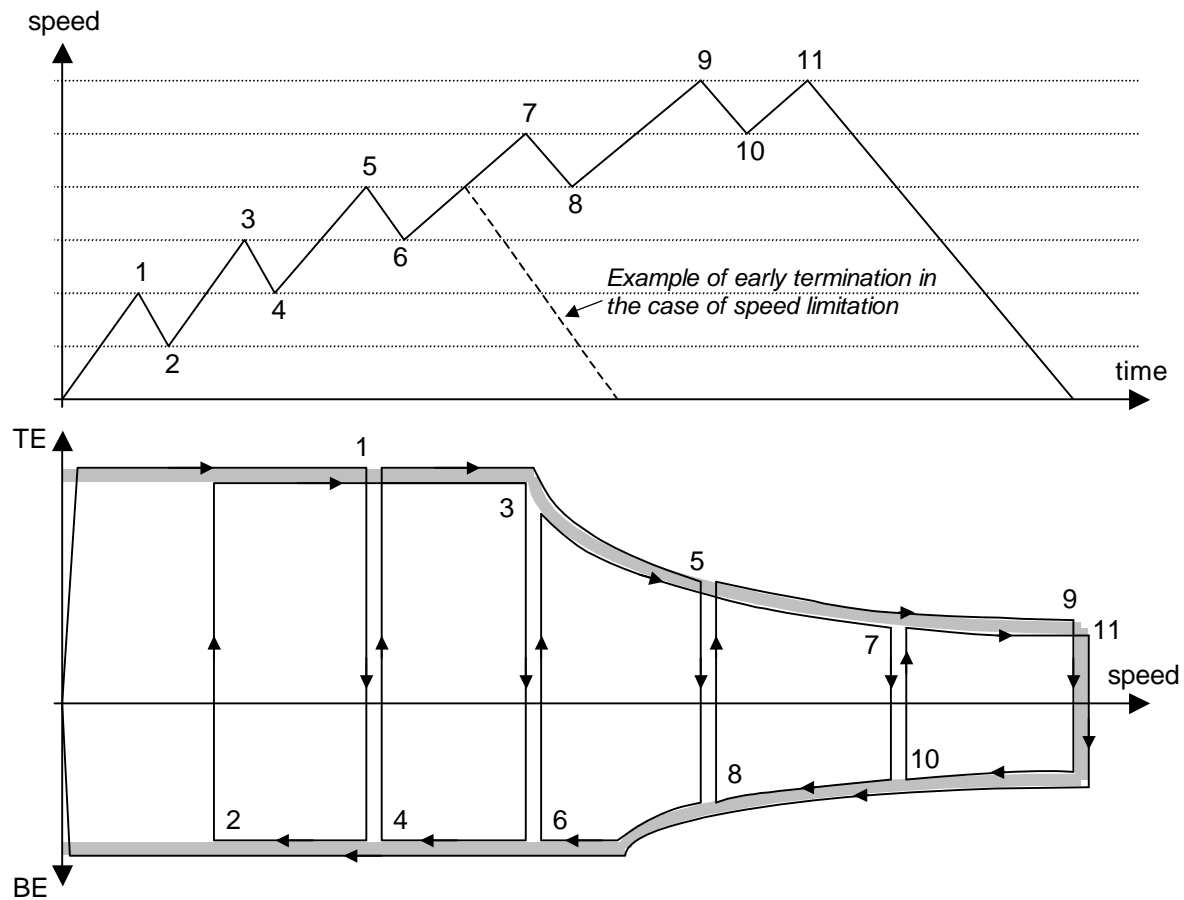

Figure 3. LOOP operation sequence.

3.3.4.6 Transformer inrush (DC) test (T5, Sweden only)

NOTE: This is not the same test that is specified for AC inrush currents in section 4.4.

The train must be located just beyond the first booster transformer, seen from the converter station, as seen in figure 4 below.

The tests shall be performed with the maximum configuration of the vehicle (i.e. maximal number of units in multiple operation for which the approval must be valid). At least 25 trials of breaker closures shall be performed, preferably more. All trials must be within limits for acceptance.

The DC-component shall be calculated as the mean value over one period of the fundamental, moving average calculation. The transducer must handle the frequencies from DC and upwards. The whole course of the inrush current shall be recorded.

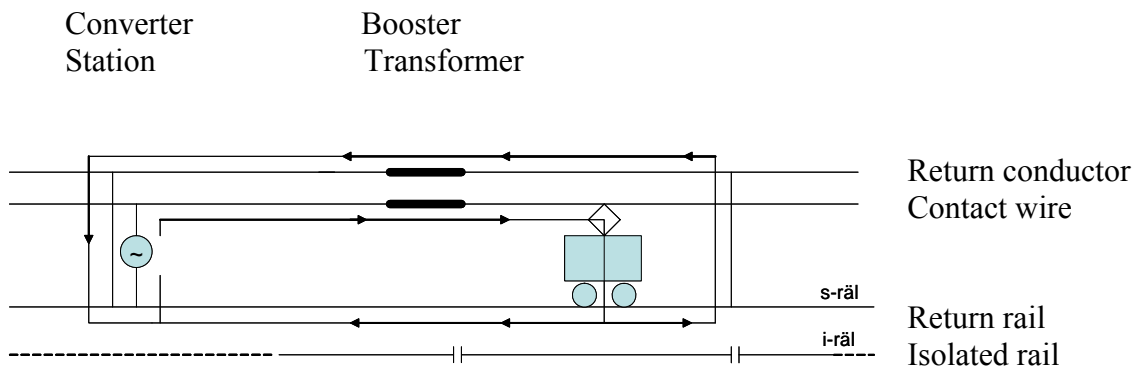

Figure 4. Train position at the inrush current test. For booster transformer data, please refer to Appendix 1, section A1.2.3, A1.2.4 and A1.5.6.

3.3.5 Measurement instrumentation and methods

3.3.5.1 Measurement instrumentation – requirements S1-S6

All measurements shall be performed with adequate voltage and current transducers (transformers and/or active transducers such as Rogowski coils and Hall transducers. Hall transducers are particularly required for DC measurements).

Sampling instruments as shown in figure 5 below are recommended. For measurements of high frequency phenomena, such as the Norwegian signalling circuit interference, a sampling frequency of approximately 50 kHz is recommended together with an anti-aliasing filter with a cut of frequency of approximately 20 kHz.

It is required that adequate anti-aliasing filters are used. The cut-off frequency of the anti-alias filter for the current measurement must be higher than the highest frequency of interest, i.e., higher than 17 kHz for Norway (FTGS track circuits) and higher than 6 kHz for Sweden (psophometric currents). The sampling frequency must be well above two times these values.

It is recommended that all raw data be streamed directly to a storage device (DAT recorder, hard-disk, or similar) for later post-processing and analysis, in addition to the on-line supervision. For the signal processing see chapter 3.3.5.2 below.

The figure below shows an example of the recommended principle of data recording and analysis, and how to install Hall transducers to measure the DC-current. It is recommended that the speed signal be taken from the vehicle control rather than via GPS, since the test lines comprise numerous tunnels without GPS coverage.

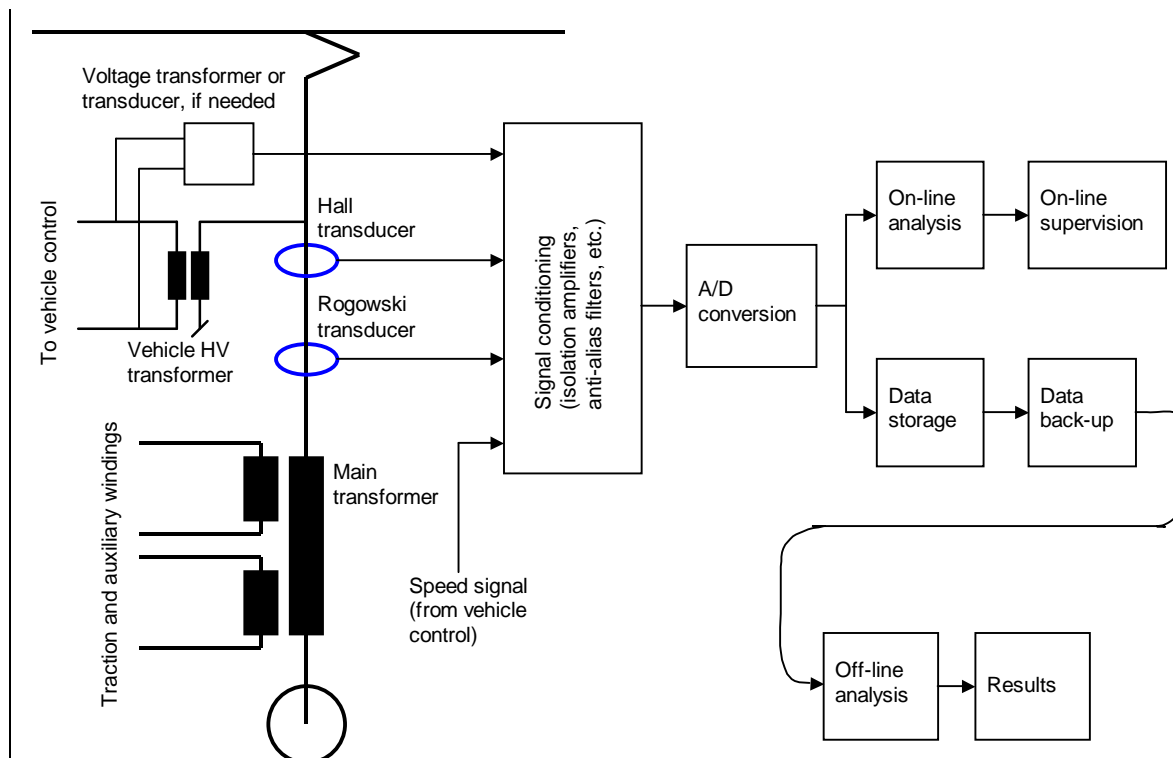

Figure 5. Transducer position and recommended measuring equipment.

The tolerance of the overall signal chain including transducers, signal conditioners, A/D converters, and data analysis, must be determined before the tests. A measurement error of less than $\pm 1\%$ at the fundamental, and less than $\pm 5\%$ of any of the stated interference requirements, is expected.

The principles of the data analysis, as well as the tolerances, must be described and presented before the tests, as a part of the test plan for the accepting authority.

3.3.5.2 Data analysis – requirements S1-S6

The recorded data must be processed and analysed in accordance with the interference requirements S1-S6. The result plots from the analysis (one or more plots per individual LOOP, ABAB, or ARO sequence) must present the following quantities, all versus time:

- RMS line current
- RMS line voltage
- Train speed
- DC current (Sweden only)
- 95 Hz and 105 Hz RMS current (Norway only)
- RMS currents in each of the 16 TI 21 channels (Norway only)

- RMS current in each of the 4 FTGS46 channels, and each of the 8 FTGS 917 channels (Norway only)
- RMS current in the broad-band interference channels. The lower channel should be split in three bands, such that the levels in the following frequency bands are presented separately: 33 Hz – 150 Hz, > 150 Hz – 300 Hz, > 300 Hz – 7 kHz, > 7 kHz – 9 kHz, > 9 kHz (Norway only)

In addition, the following information must be given in each plot:

- Test date
- Line section
- Test ID (reference to the test log)
- Status of the vehicle (number of converters in operation, software revision etc.)
- Distance covered during the test sequence
- 99%-percentile of the psophometric current

If the psophometric current varies significantly with speed (e.g., in the case of a rectifier vehicle), the test report must additionally present a plot of the psophometric current versus speed.

Figure 6 below shows the suggested analysis method, based on a sampling frequency of the raw data of 50 kHz.

For FFT analysis, Hanning windows are recommended.

It is suggested that the psophometric currents are determined by means of a digital IIR filter with a characteristic equal to that specified by Appendix 9. It must be documented that the gain of the filter complies with the tolerance specified in ITU-T O.41 throughout the frequency band 50 Hz – 6 kHz. The recommended RMS integration time is 140 ms.

If FFT methods are used, the psophometric weighting function according to ITU-T (see Appendix 9) shall be applied on the FFT bins according to the formula in section 3.2.5. For FFT bins between the frequencies for which the weighting factors are specified, linearly interpolated values shall be used. The recommended FFT window length is 120 ms. At least 50% overlapping is required. The applicant shall describe how he deals with spectral leakage and frequency variations.

Other types of measurement and evaluation methods, than the recommendations above, can be discussed, but the applicant must then show how these measurements will be carried out and what accuracy will be achieved.

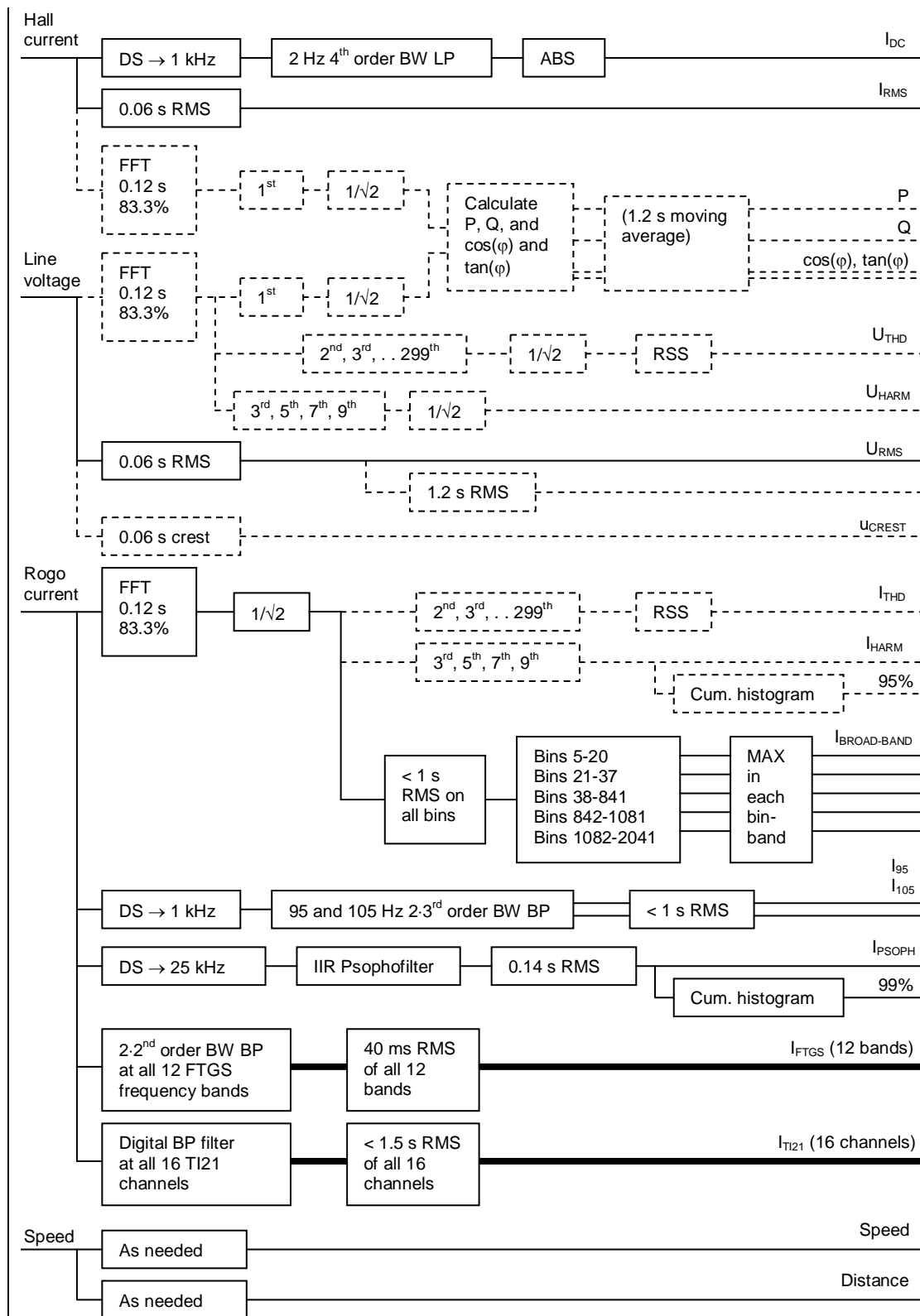

Figure 6. Suggested post-processing of the recorded data.

3.3.5.3 Data analysis – S1-requirement (transformer inrush)

The current and voltage waveforms, as well as the 60 ms moving average value of the current, around each inrush event must be plotted, and the time for the 60 ms moving average value of the current exceeding plus or minus 25.0 A must be noted. Each plot must have information about the test date, the exact location of the test, and the data recording ID(s).

3.3.5.4 Measurements and analysis – S7-requirement

Measurements procedures and instrumentation are in accordance with EN 50 121, part 2 and 3-1.

3.4 Documentation

3.4.1 General

All documentation shall be in English. The documentation shall contain:

- Technical functional descriptions, when required
- Measuring equipment
- Accuracy
- Calibration
- Test set up (trains other locos and so on)
- Software version on vehicle
- Time and date for the tests
- Track/line sections and distance from start of line for the presented registrations
- Information about number of repetitions and approximate location for the various tests. Based on this, the applicant must evaluate whether the results can be considered as typical and representative for the later use of the rolling stock, or if special conditions not included in the tests may potentially lead to future problems.
- Discussion of the results and evaluation and a conclusion whether each requirement is fulfilled or not, i.e. a confirmative statement for each requirement.
- A summary report (or a summary as a part of the whole report) where the test results are summarized with remarks and observations, especially incompatibilities and exceedances of limits.

Furthermore, a general technical description containing a principle block diagram of the traction circuits of the vehicle is required.

4 POWER SUPPLY

(Applies to “Energy” only. Please see JD590 chapter 4).