

1	FJÆRER	2
1.1	Pandrol FC1501 Fastclip	2
1.2	Pandrol e1877	2
1.3	Pandrol PR341a	3
1.4	Pandrol PR607a	3
1.5	Pandrol PR323	4
1.6	Pandrol PR401	4
1.7	Pandrol e2039	5
1.8	Hey-Back Fjær - HBFJ35	5
1.9	Hey-Back HBFJ49	6
1.10	Hey-Back HBFJ49B	6
1.11	Hey-Back HBFJ54	7
1.12	Dobbel fjærspiker Dn4	7
1.13	Nabla fjærblad - RNTN1	8
2	ISOLATORER	9
2.1	Pandrol Fastclip isolatorer for UIC60/S54/S49	9
2.2	Pandrol isolator for UIC60 på NSB 93	10
2.3	Pandrol isolator for S54 på NSB 90	10
2.4	Pandrol isolator for S41/S49 på NSB 90	11
2.5	Pandrol isolator For S41/S49 på NSB ENHETSSVILLE	11
2.6	Pandrol isolator for S54 på NSB ENHETSSVILLE	12
2.7	Pandrol isolator for S41/S49/S54 på NSB ENHETSSVILLE	12
2.8	Pandrol isolator for 35 kg/NSB40 på NSB ENHETSSVILLE	13
2.9	Pandrol isolator for S49 på betongsville i sporveksel	13
3	MELLOMLEGG	14
3.1	Pandrol 10 mm mellomlegg for UIC60 / Fastclip / NSB 95	14
3.2	Pandrol 10 mm mellomlegg for UIC60 / e-clip / NSB 93	14
3.3	Pandrol 10 mm mellomlegg for S49/S54 / Fastclip / JBV 97	15
3.4	Pandrol 10 mm mellomlegg for S49/S54 / e-clip / NSB 90	15
3.5	Walker 10 mm mellomlegg for S49/S54 / e-clip / NSB 90	16
3.6	6,5 mm mellomlegg for S54 / e-clip / NSB ENHETSSVILLE	16
3.7	EVA 5 mm mellomlegg for 35 kg/NSB40/S41/S49/S54 / PR-clip	17
3.8	EVA 5 mm mellomlegg for 35 kg/NSB40 / PR-clip	17
3.9	EVA 5 mm mellomlegg for S49 i sporveksler	18
4	UNDERLAGSPLATER	19
4.1	Pandrol underlagsplate for S49/S54 på tresviller	19
4.2	Hey-Back underlagsplate for S41/S49/S54 på tresviller	19
4.3	Hey-Back underlagsplate for 35 kg/NSB40 på tresviller	20
4.4	Hey-Back underlagsplate for S41/S49 på betongsville type 2	20
5	SVILLESKRUER	21
5.1	Svilleskrue for underlagsplate på tresviller	21
5.2	Svilleskrue for underlagsplate på betongsviller	21
5.3	Svilleskrue for Nabla på tresviller	22

1 FJÆRER

1.1 Pandrol FC1501 Fastclip

Tegning: Sk 3161 Farge: Blå

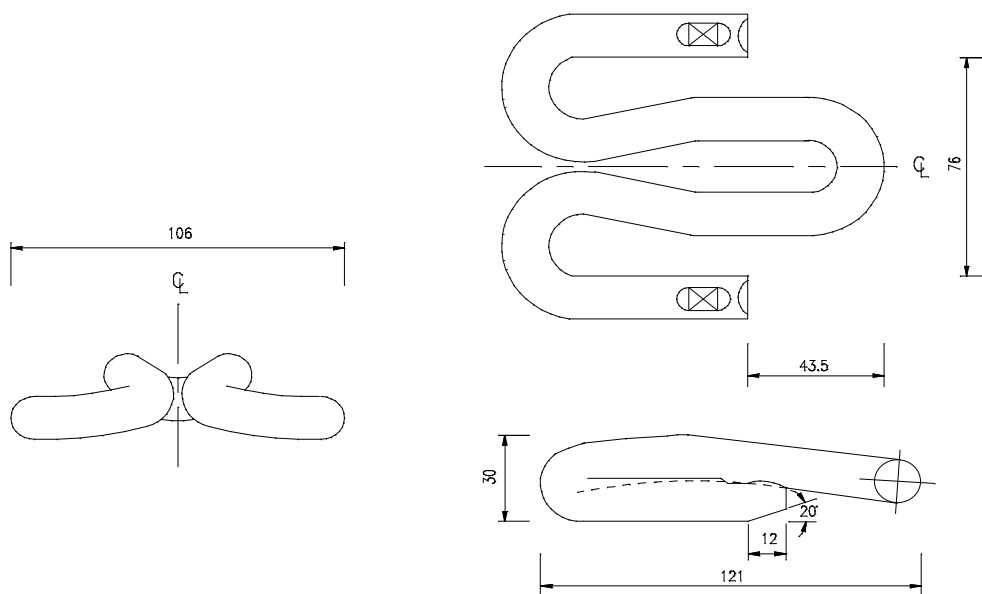

1.2 Pandrol e1877.

Tegning: Sk 3100 Farge: Blå

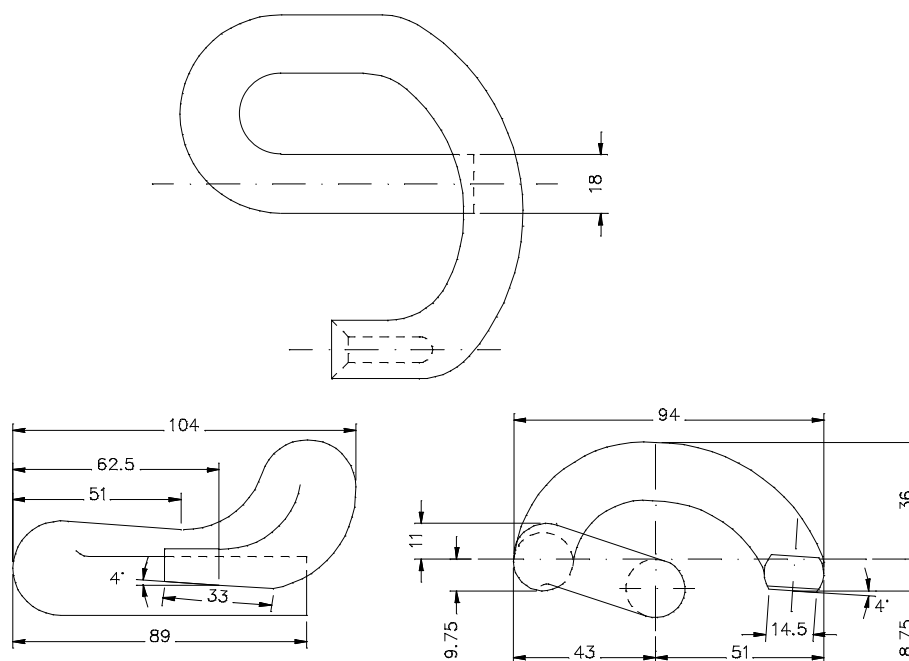

1.3 Pandrol PR341a

Tegning: Sk 1584 Farge: Svart

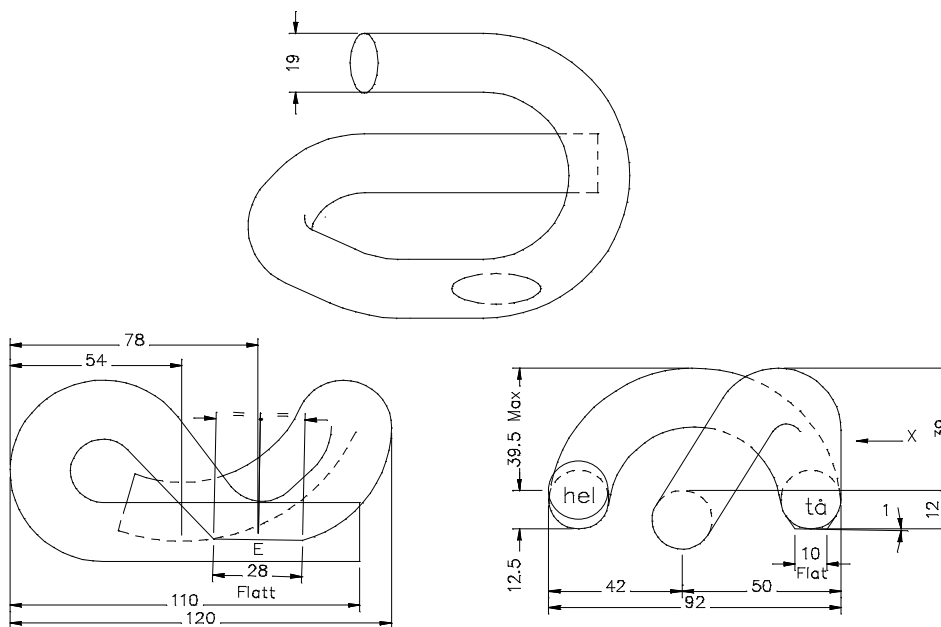

1.4 Pandrol PR607a

Tegning: Sk 1572 Farge: Svart

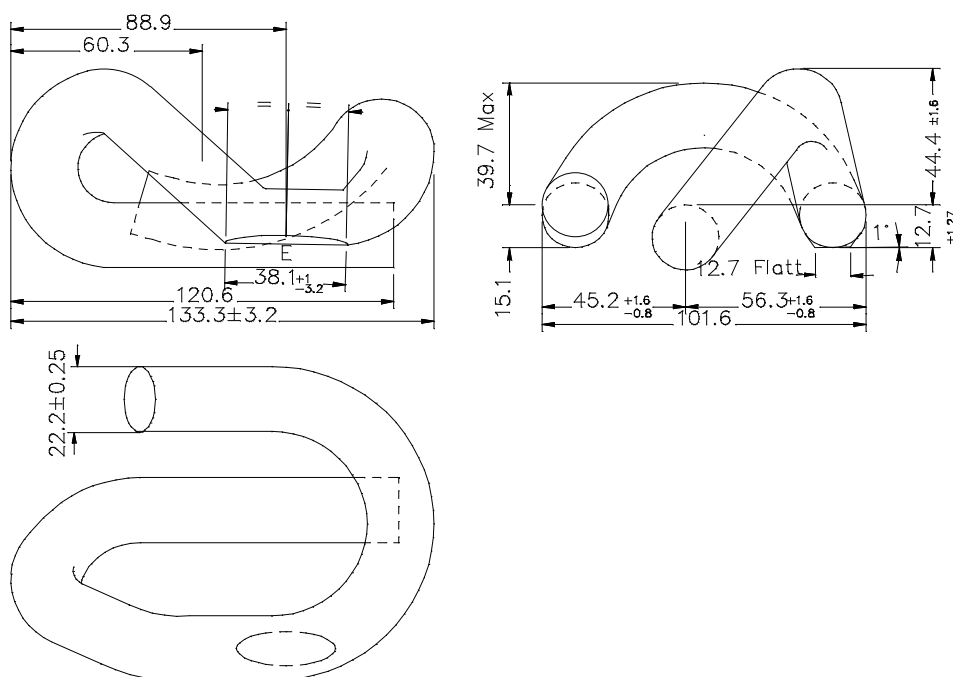

1.5 Pandrol PR323

Tegning: Sk1573 Farge: Svart

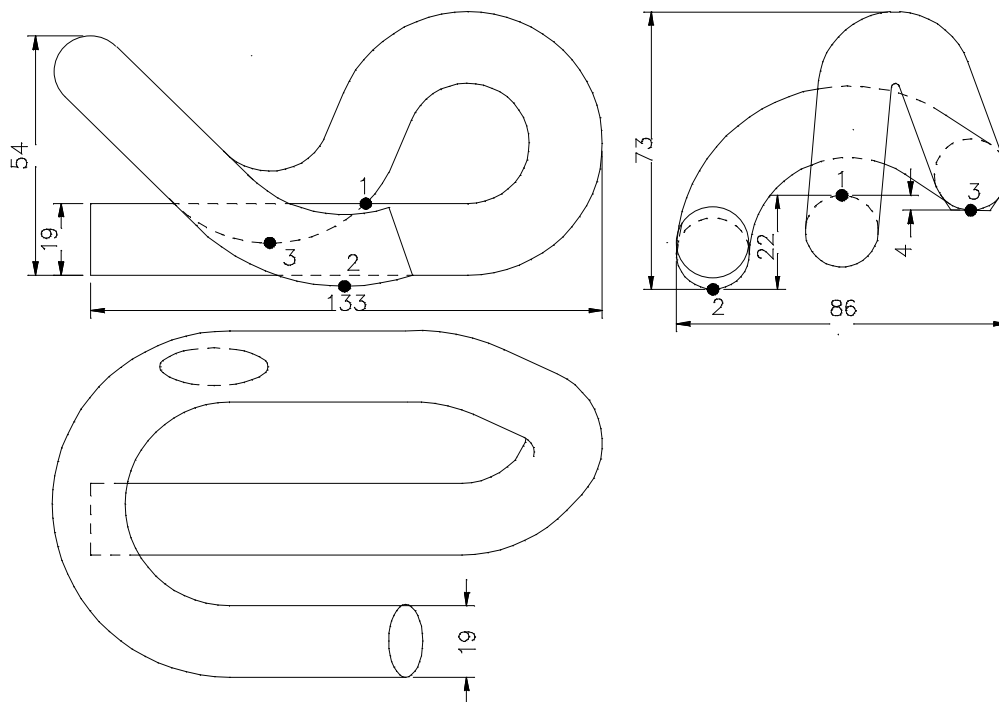

1.6 Pandrol PR401

Tegning: Sk 1574 Farge: Svart

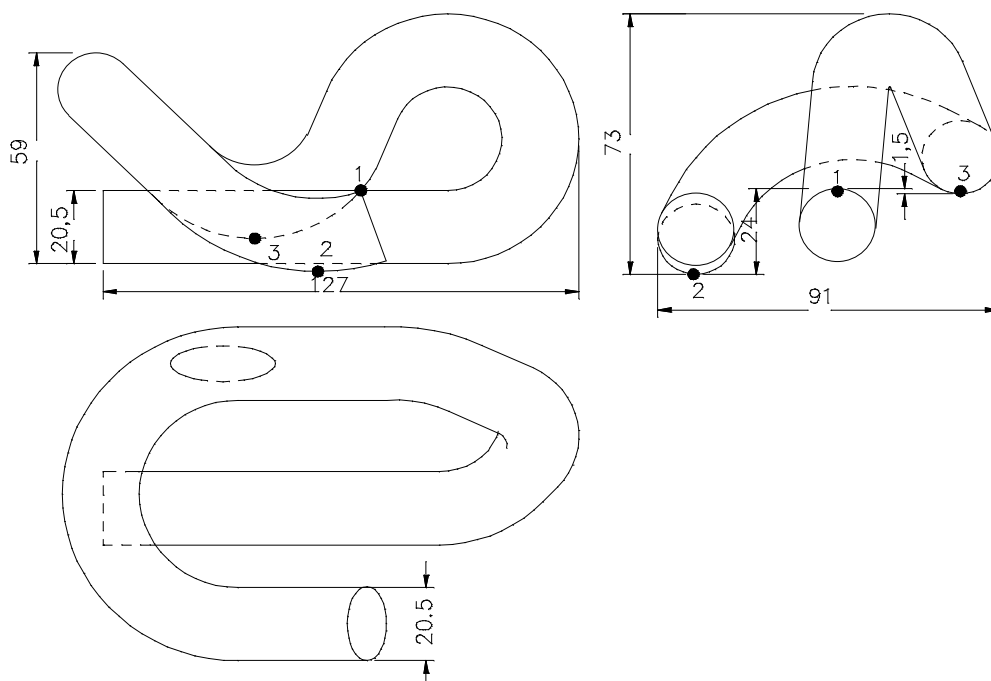

1.7 Pandrol e2039

Tegning: Sk 2039 Farge: Grønn

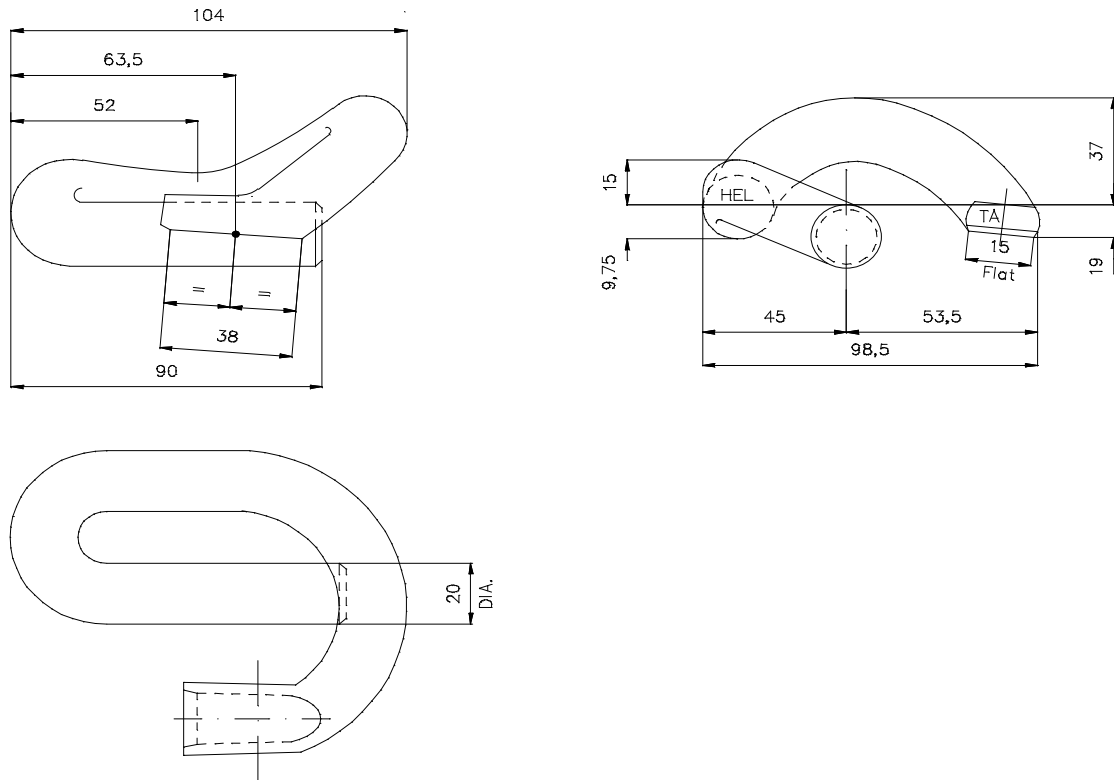

1.8 Hey-Back Fjær - HBFJ35

Tegning: Sk 1576

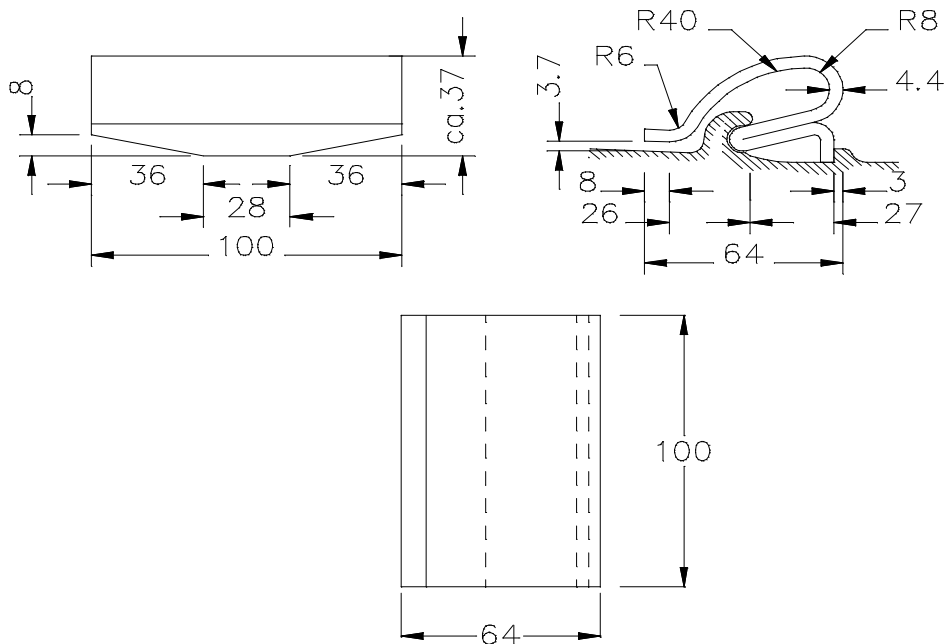

1.9 Hey-Back HBFJ49

Tegning: Sk 1577

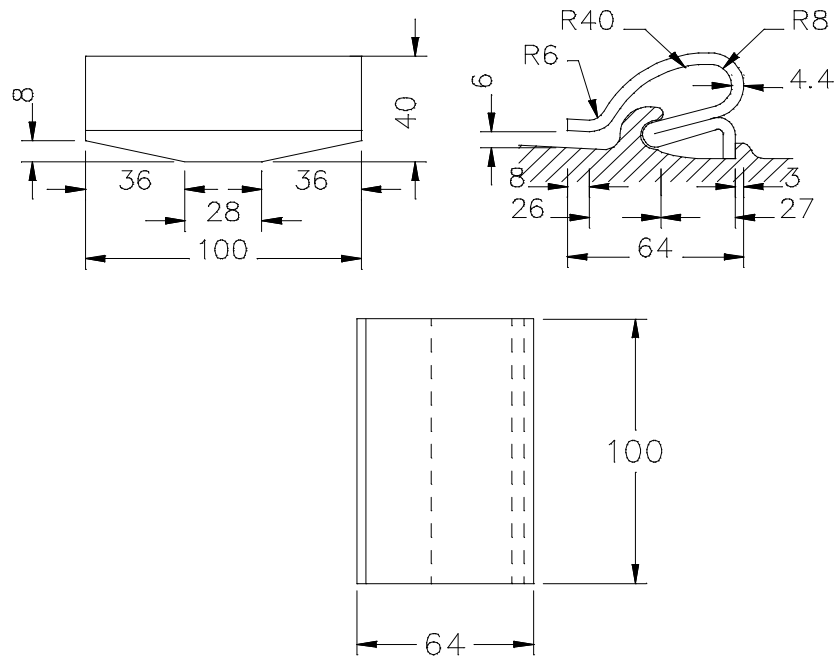

1.10 Hey-Back HBFJ49B

Tegning: Sk 1575

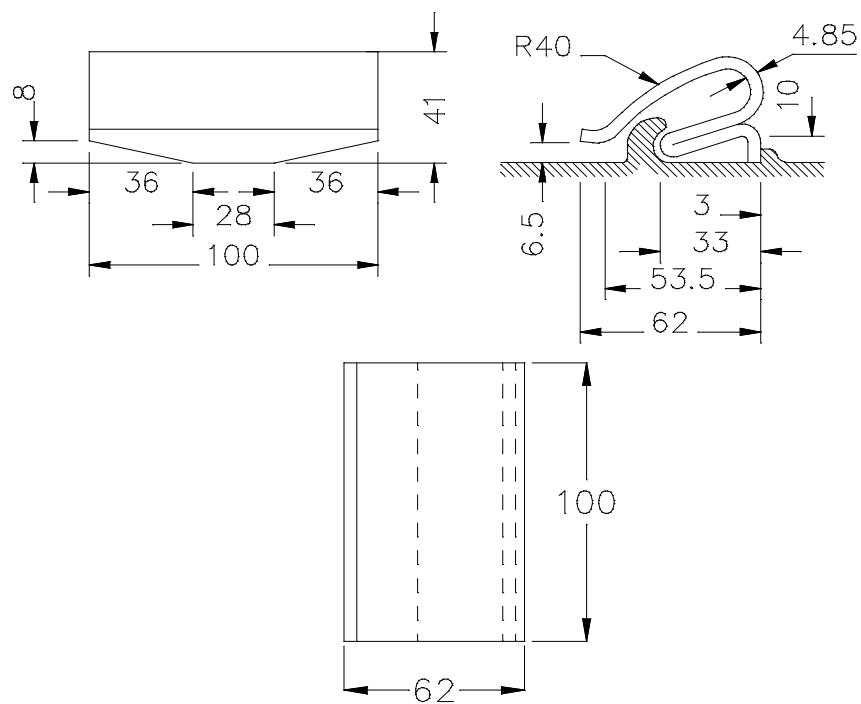

1.11 Hey-Back HBFJ54

Tegning: Sk 1578

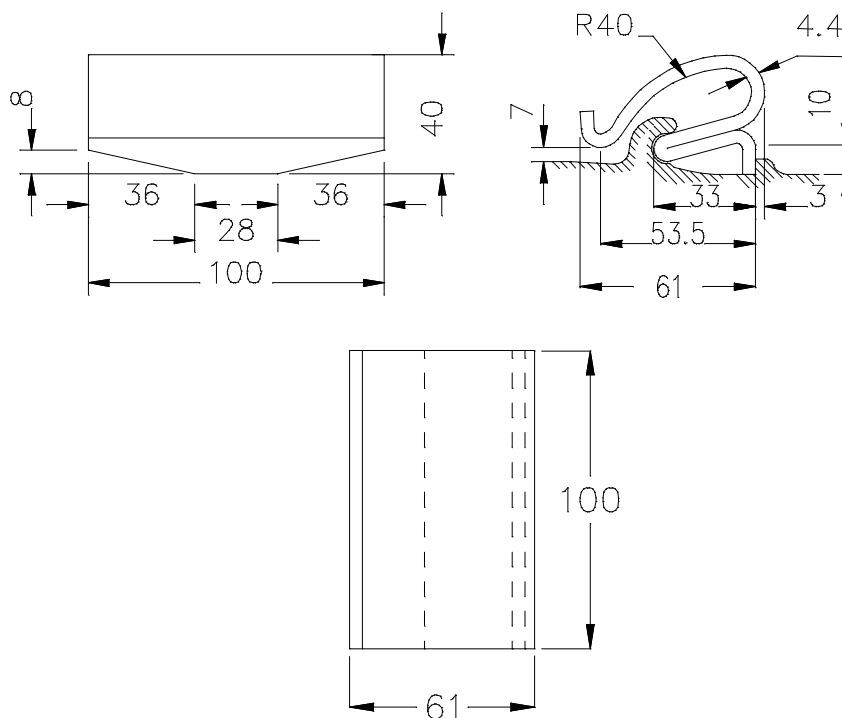

1.12 Dobbel fjærspiker Dn4

Tegning: Sk 1579

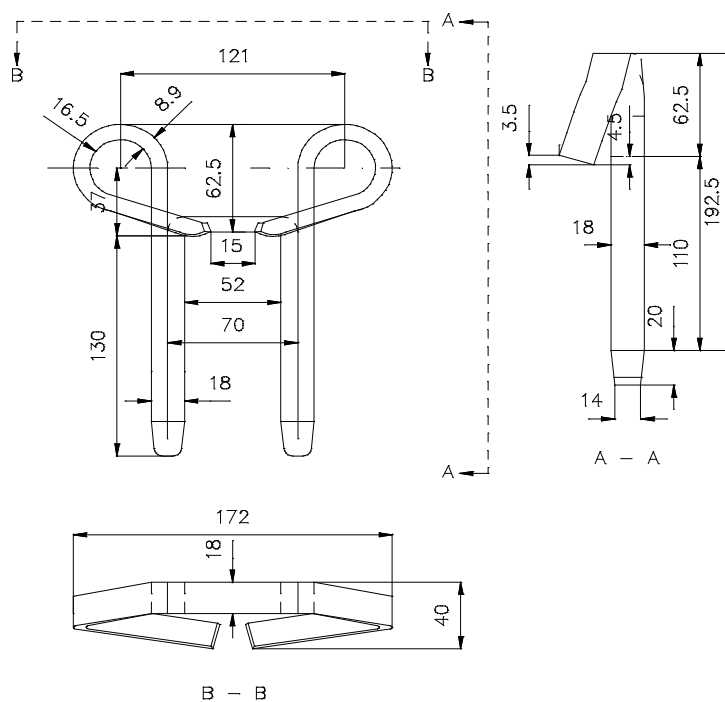

1.13 Nabla fjærblad - RNTN1

Tegning: Sk 3140

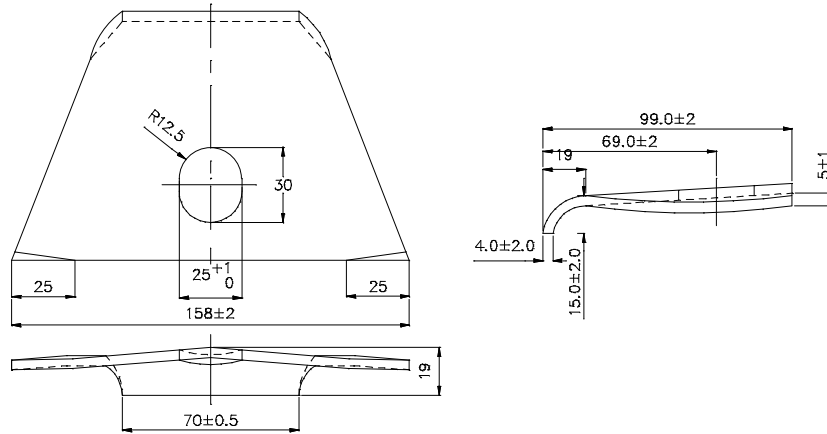

UNDERLAGSPLATE I BAKKANT AV FJÆREN

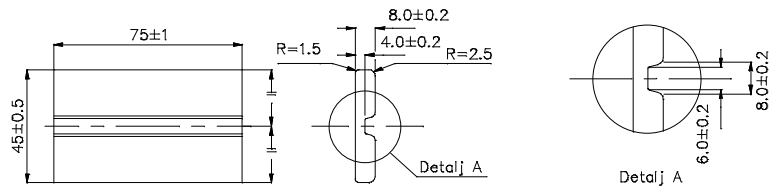

2 ISOLATORER

2.1 Pandrol Fastclip isolatorer for UIC60/S54/S49

Tåisolator: Sk 3162a, Sideisolator: Sk 3163

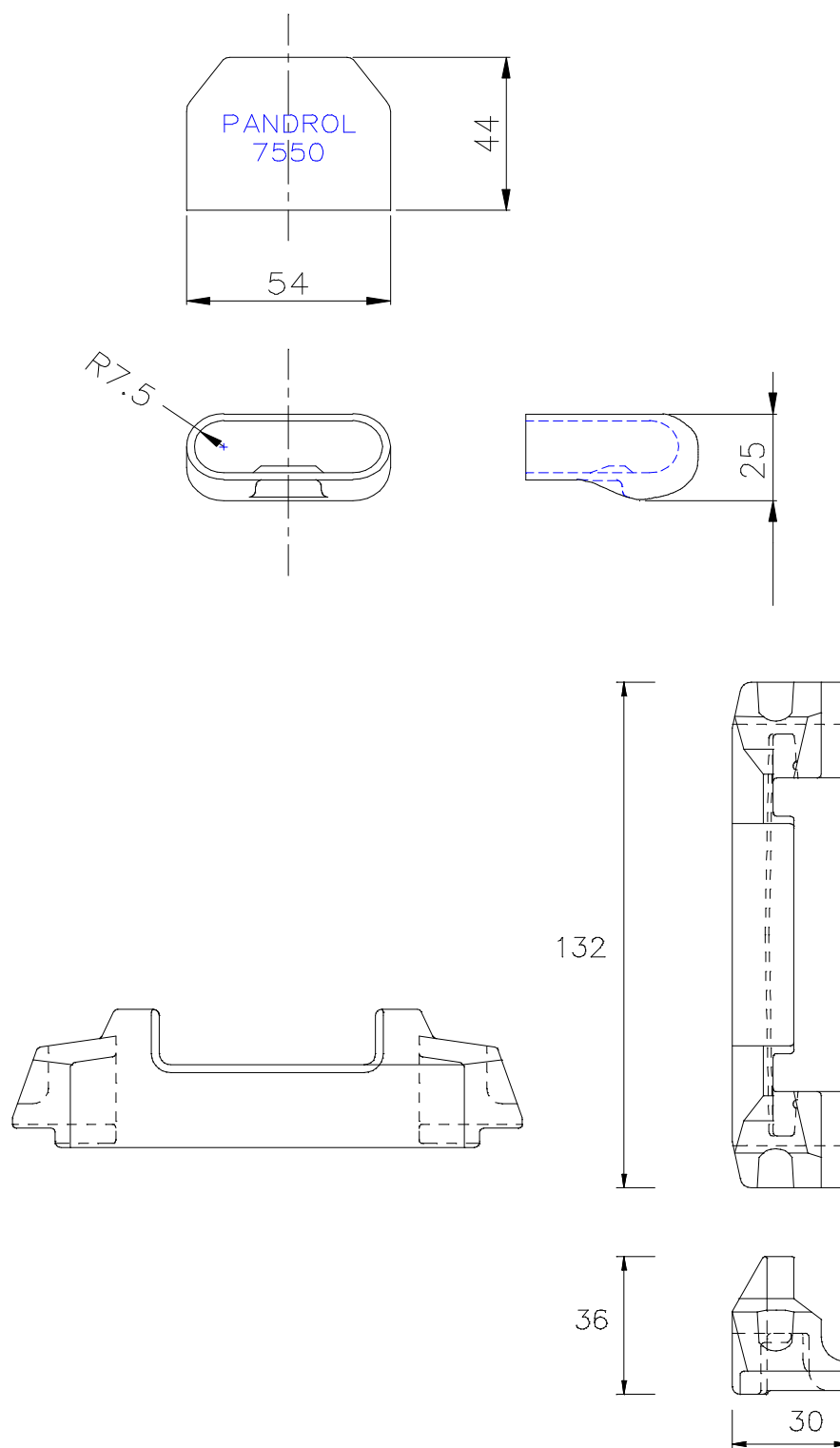

2.2 Pandrol isolator for UIC60 på NSB 93

Tegning: Sk 3125

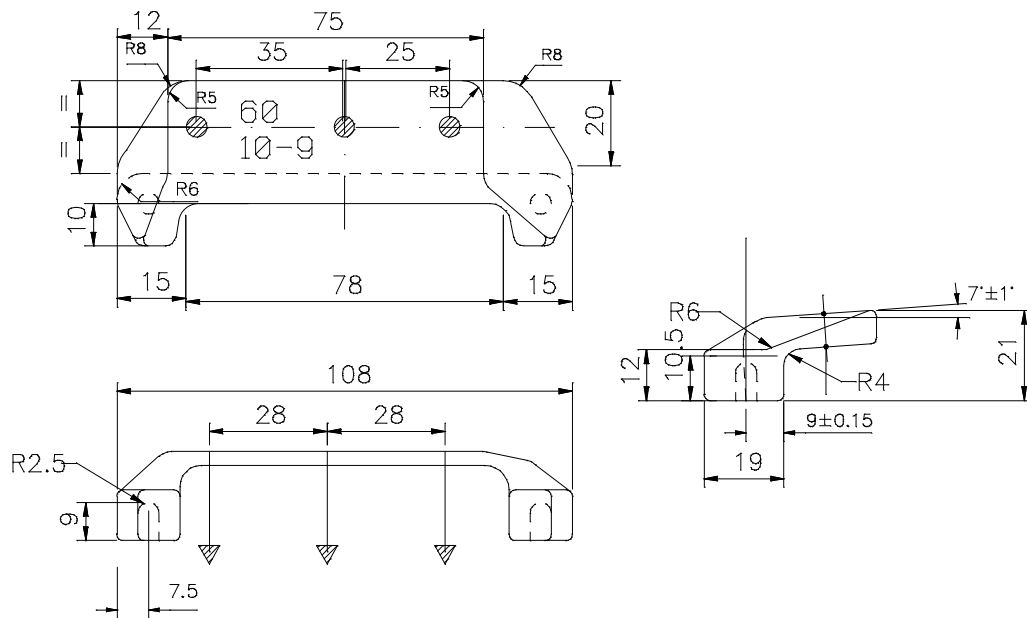

2.3 Pandrol isolator for S54 på NSB 90

Tegning: Sk 3109

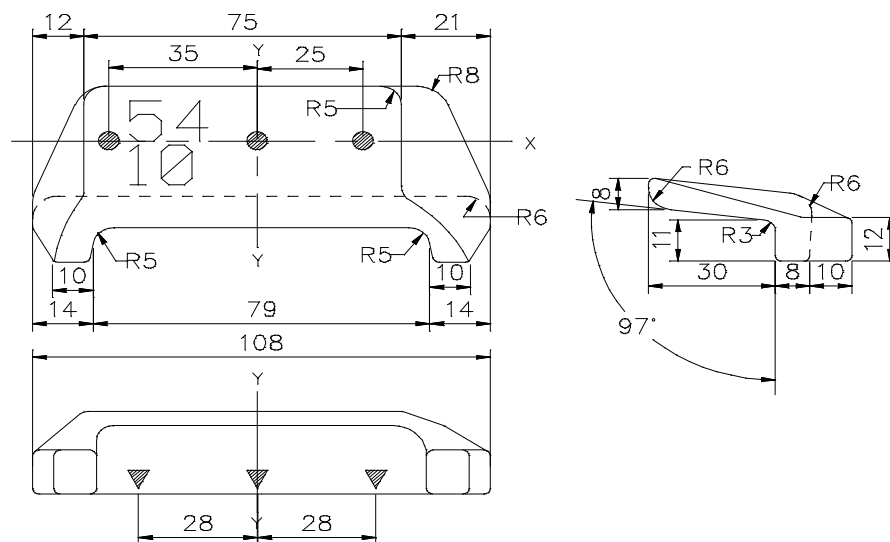

2.4 Pandrol isolator for S41/S49 på NSB 90

Tegning: Sk 3107

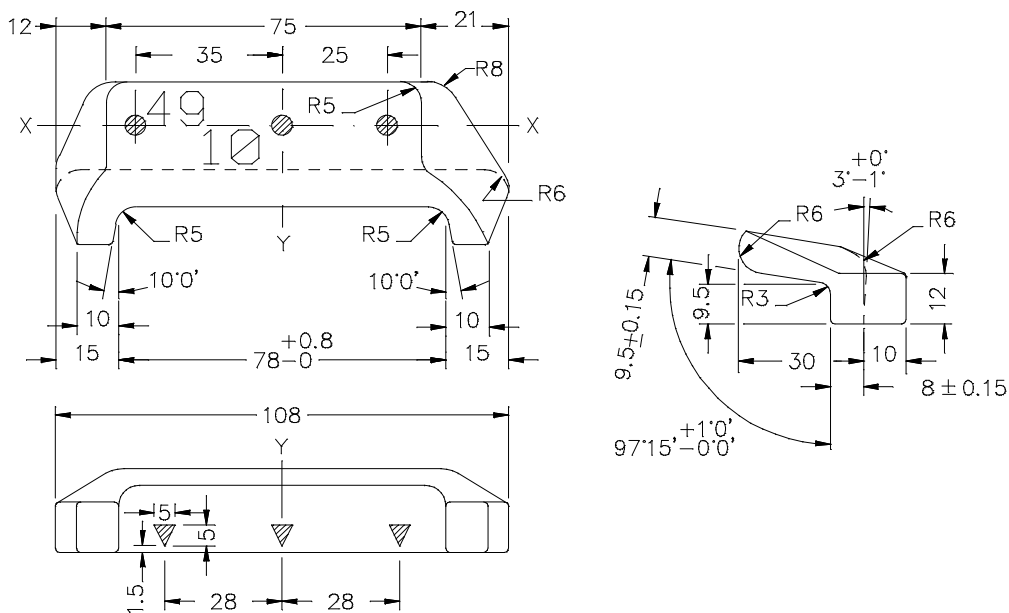

2.5 Pandrol isolator For S41/S49 på NSB ENHETSSVILLE

(Anvendes sammen med pandrolfjær e1877)

Tegning: Sk 3101

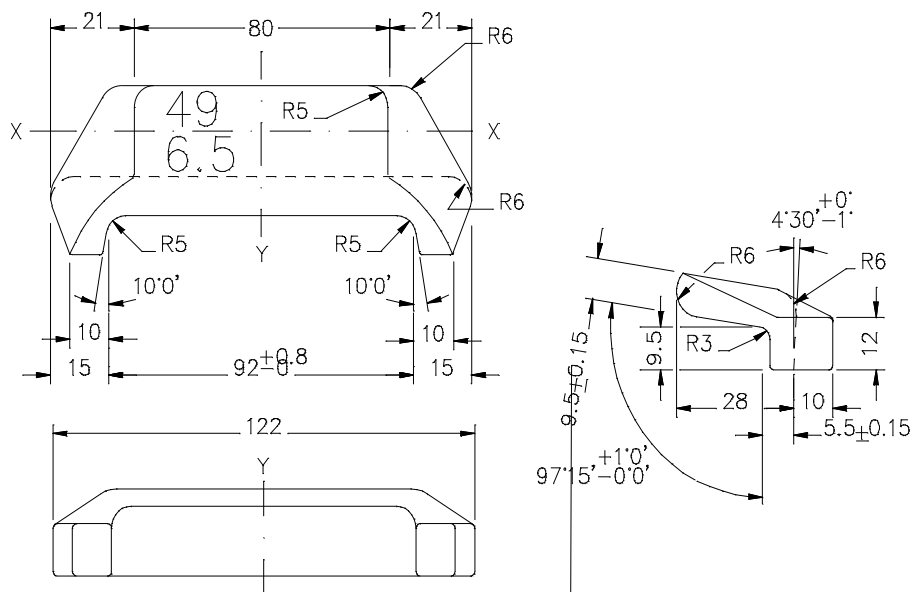

2.6 Pandrol isolator for S54 på NSB ENHETSSVILLE

(Anvendes sammen med pandrolfjær e1877)

Tegning: Sk 3103

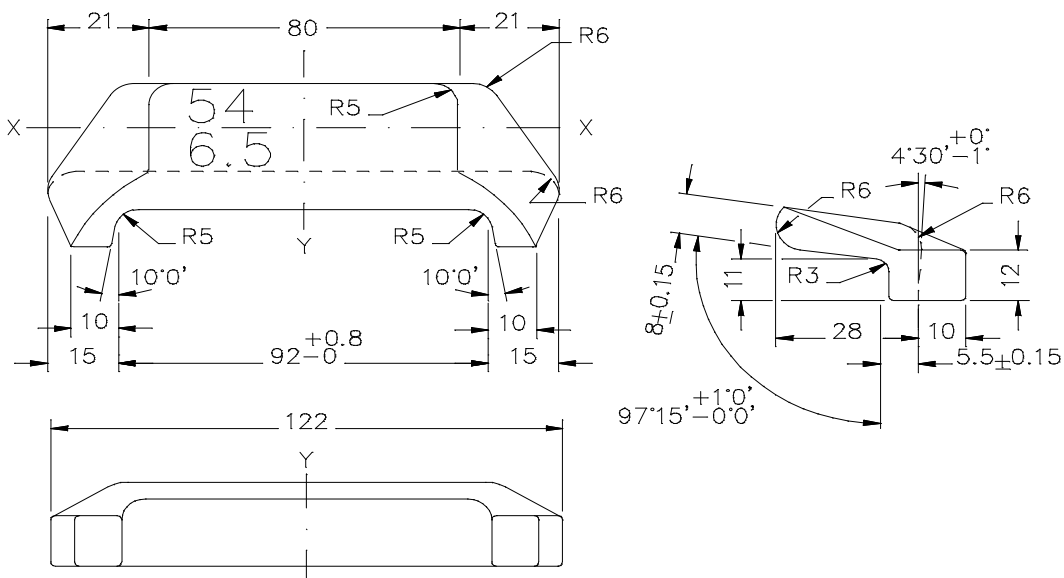

2.7 Pandrol isolator for S41/S49/S54 på NSB ENHETSSVILLE

(Anvendes sammen med pandrolfjær PR341A)

Tegning: Sk 3117

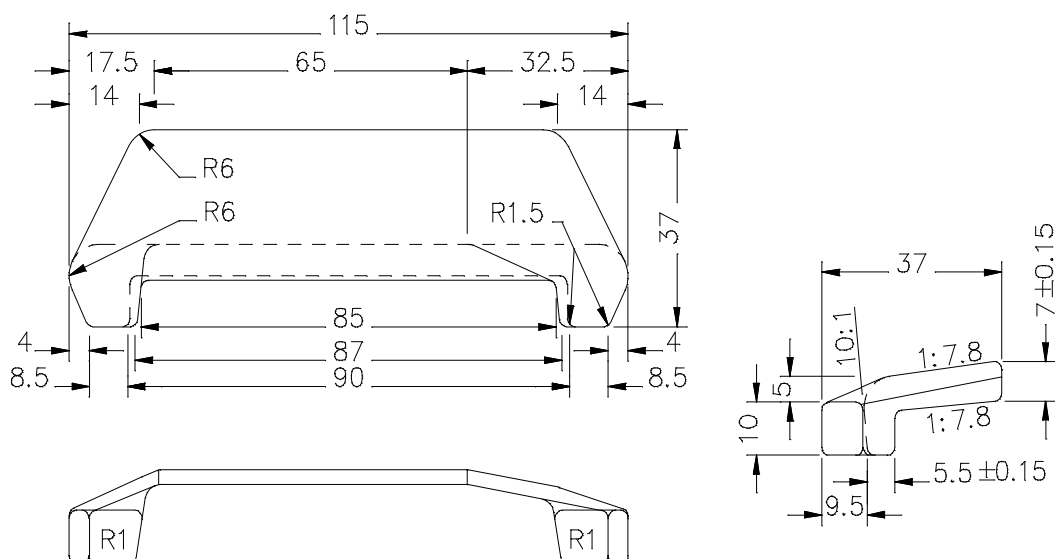

2.8 Pandrol isolator for 35 kg/NSB40 på NSB ENHETSSVILLE

(Anvendes sammen med pandrolfjær PR341A)

Tegning: Sk 1587

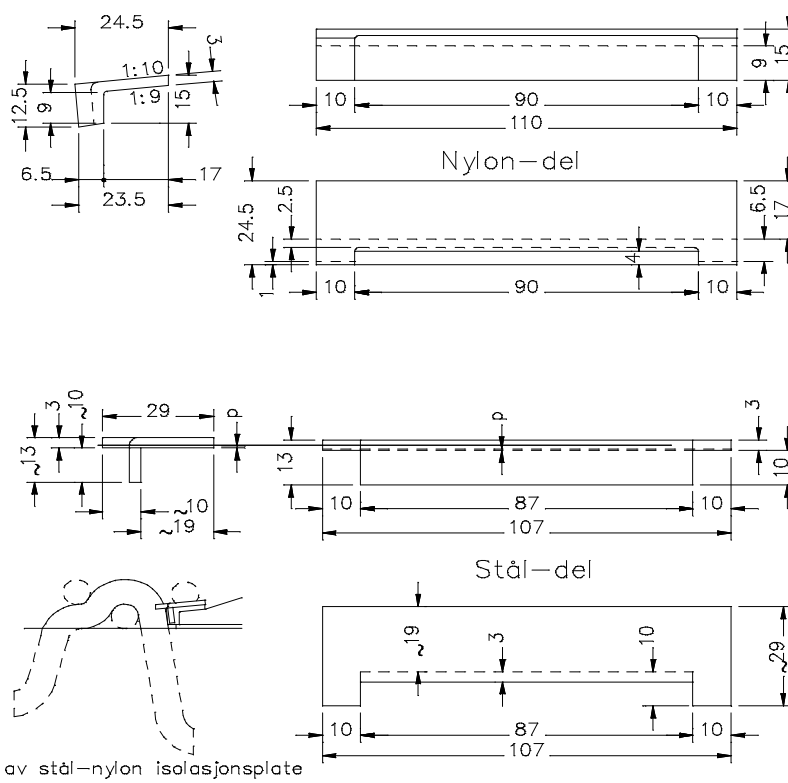

2.9 Pandrol isolator for S49 på betongsville i sporveksel

(Anvendes sammen med pandrolfjær PR341A)

Tegning: Sk 1581

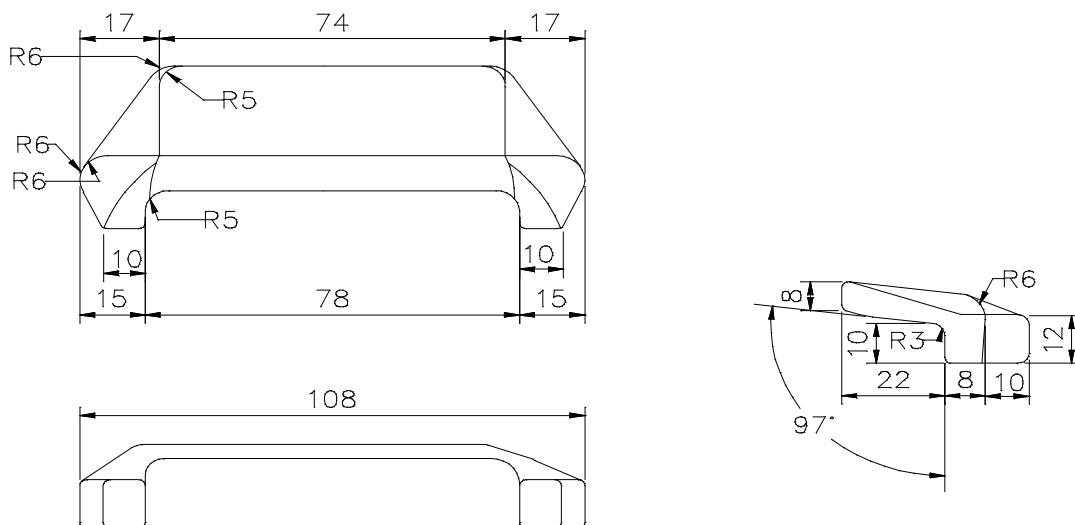

3 MELLOMLEGG

3.1 Pandrol 10 mm mellomlegg for UIC60 / Fastclip / NSB 95

Tegning: Sk 3164

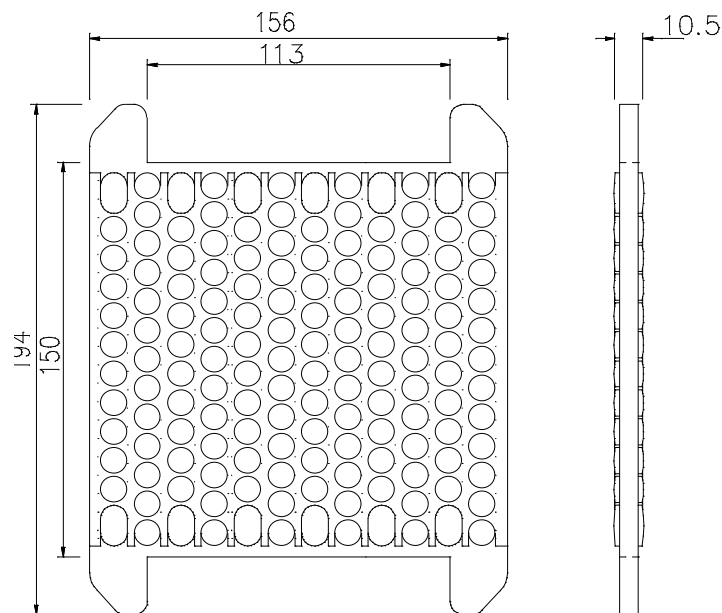

3.2 Pandrol 10 mm mellomlegg for UIC60 / e-clip / NSB 93

Tegning: Sk 3125

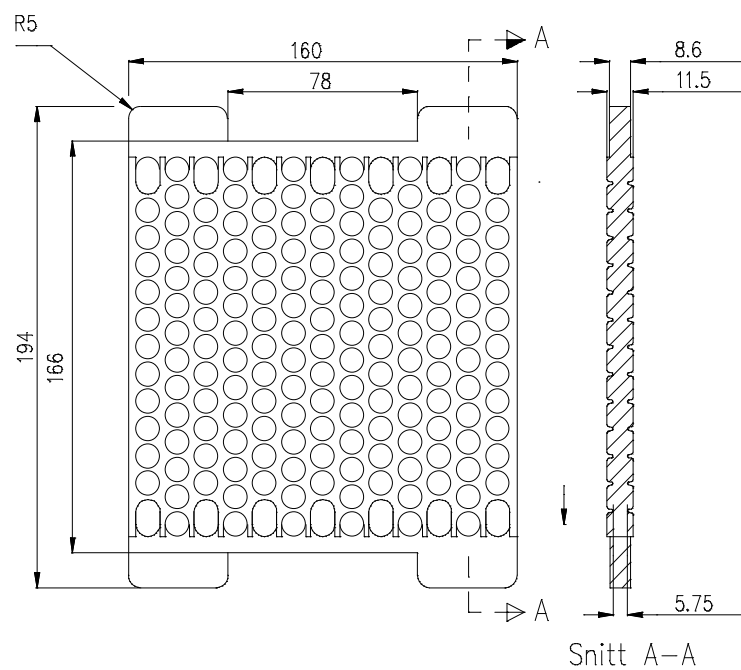

3.3 Pandrol 10 mm mellomlegg for S49/S54 / Fastclip / JBV 97

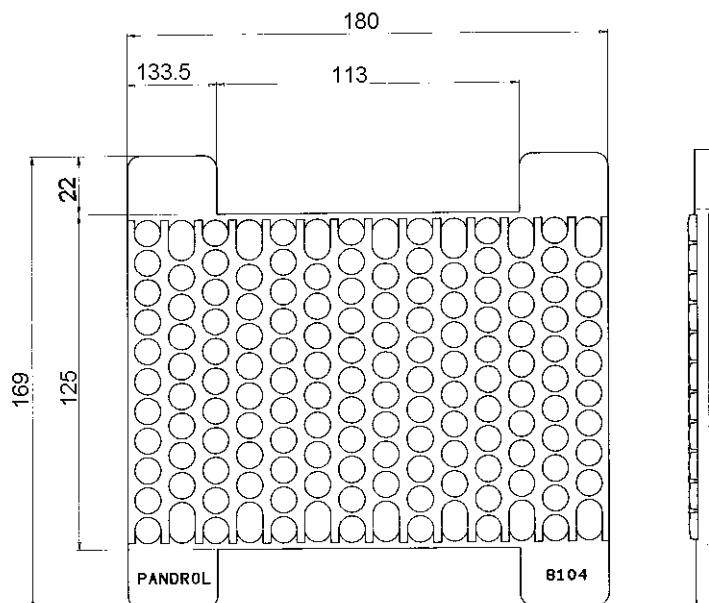

3.4 Pandrol 10 mm mellomlegg for S49/S54 / e-clip / NSB 90

Tegning: Sk 3111

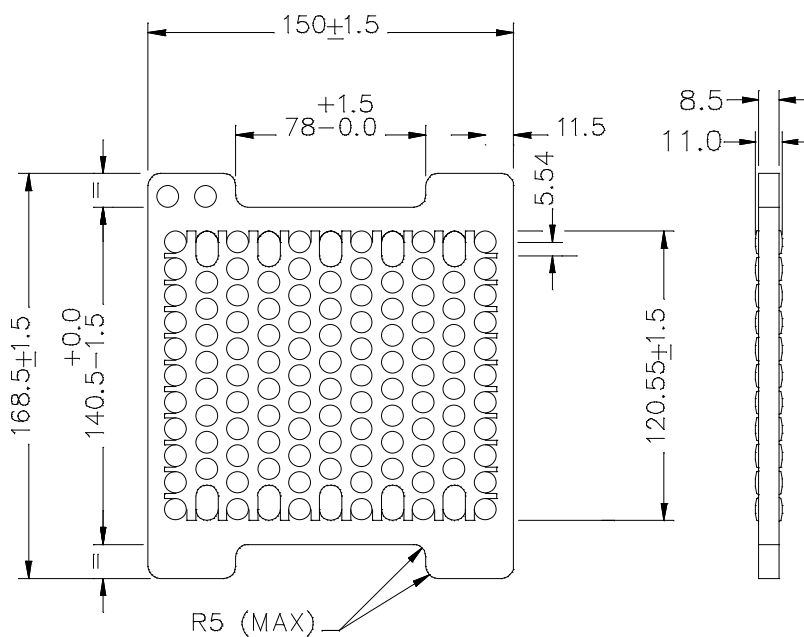

3.5 Walker 10 mm mellomlegg for S49/S54 / e-clip / NSB 90

Tegning: Sk 3119

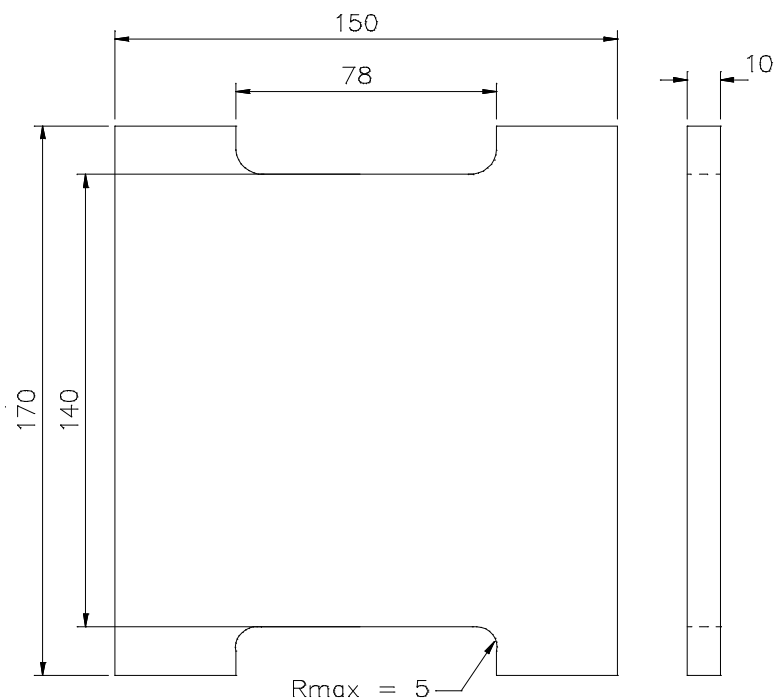

3.6 6,5 mm mellomlegg for S54 / e-clip / NSB ENHETSSVILLE

Tegning: Sk 3169

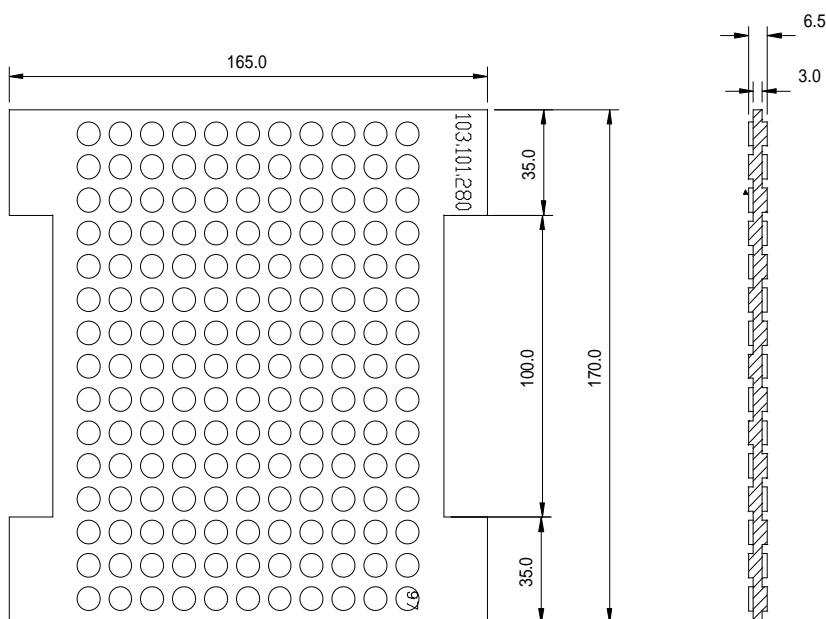

3.7 EVA 5 mm mellomlegg for 35 kg/NSB40/S41/S49/S54 / PR-clip

Tegning: Sk 1632

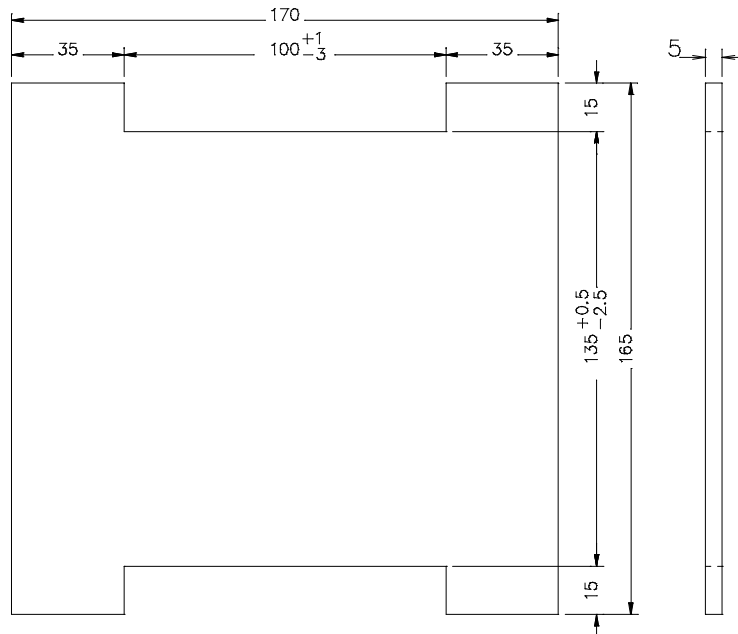

3.8 EVA 5 mm mellomlegg for 35 kg/NSB40 / PR-clip

(Anvendes for enhetssville i spesialutførelse)

Tegning: Sk 1629

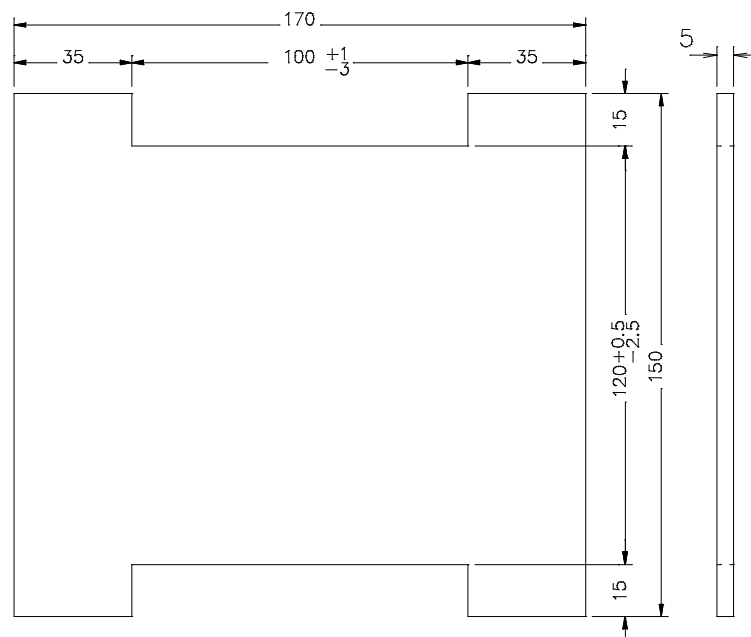

3.9 EVA 5 mm mellomlegg for S49 i sporveksler

Tegning: Sk 1579

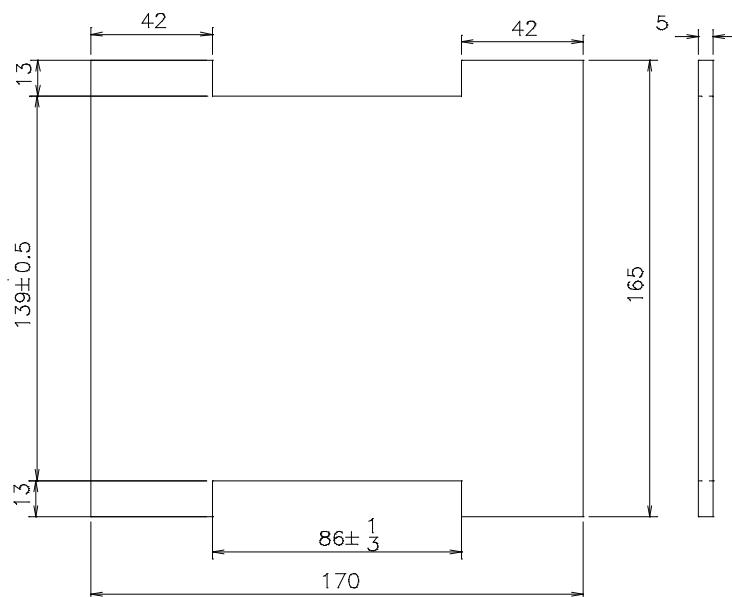

4 UNDERLAGSPLATER

4.1 Pandrol underlagsplate for S49/S54 på tresviller

Tegning: Sk 3131

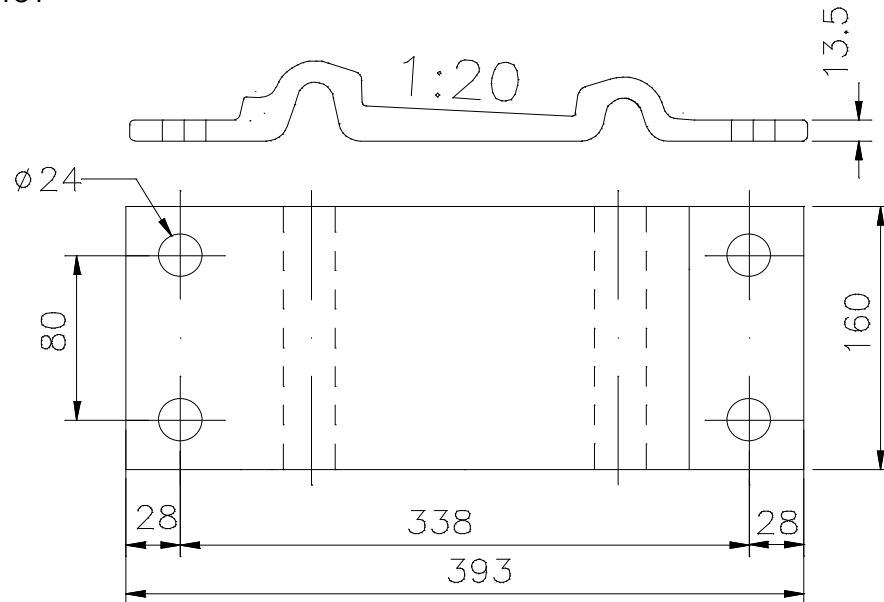

4.2 Hey-Back underlagsplate for S41/S49/S54 på tresviller

Tegning: Sk 691

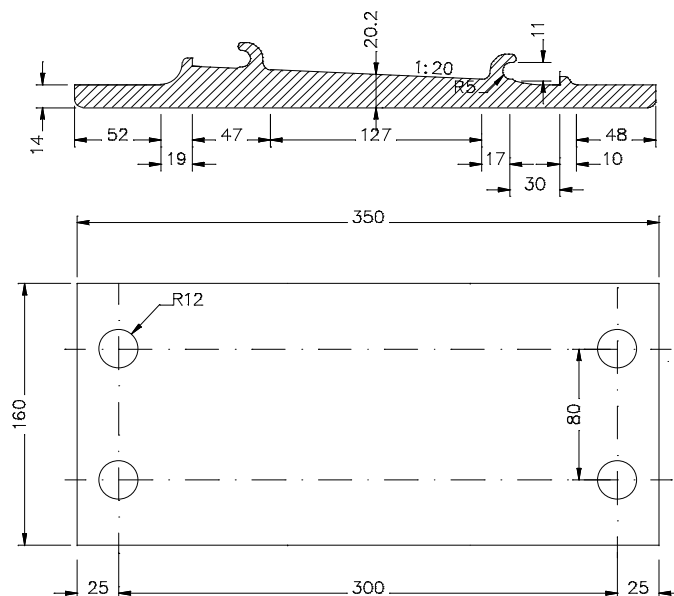

4.3 Hey-Back underlagsplate for 35 kg/NSB40 på tresviller

Tegning: Sk 695

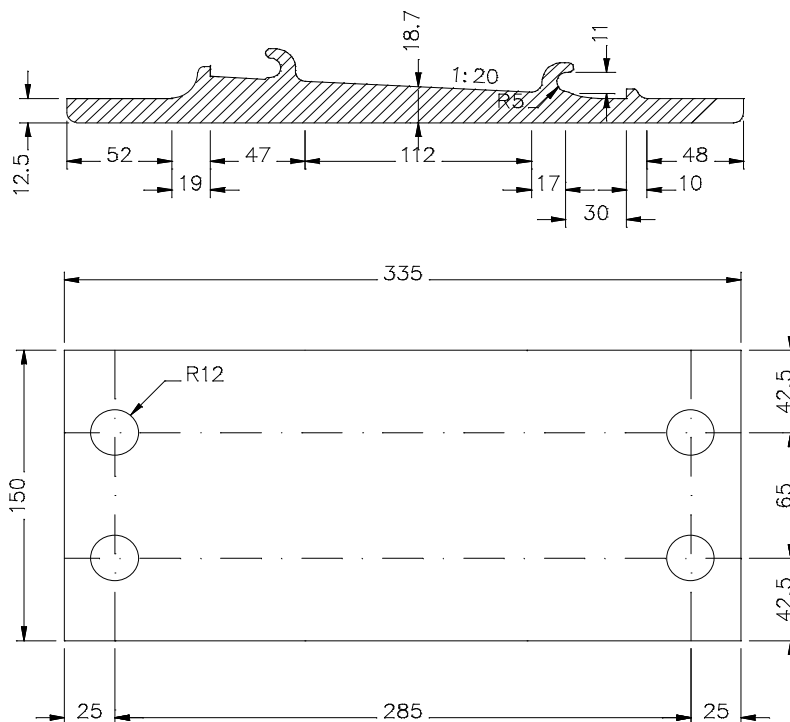

4.4 Hey-Back underlagsplate for S41/S49 på betongsville type 2

Tegning: Sk 972

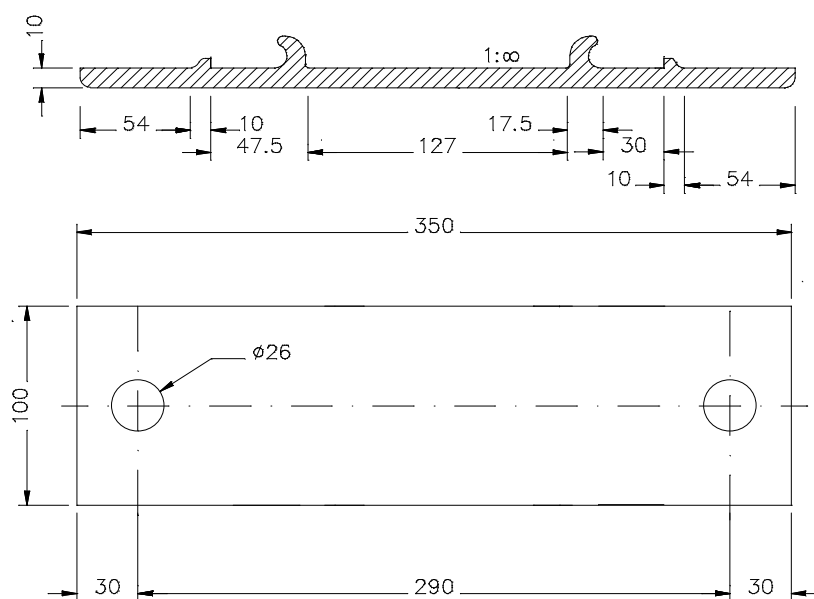

5 SVILLESKRUER

5.1 Svilleskrue for underlagsplate på tresviller

Tegning: Sk 1086

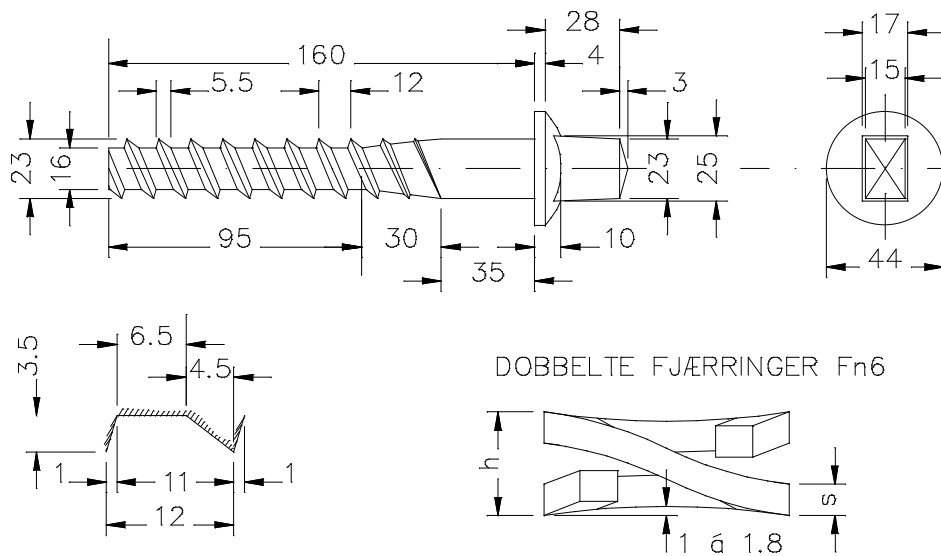

Gjenge-detalj

5.2 Svilleskrue for underlagsplate på betongsviller

Tegning: Sk 946

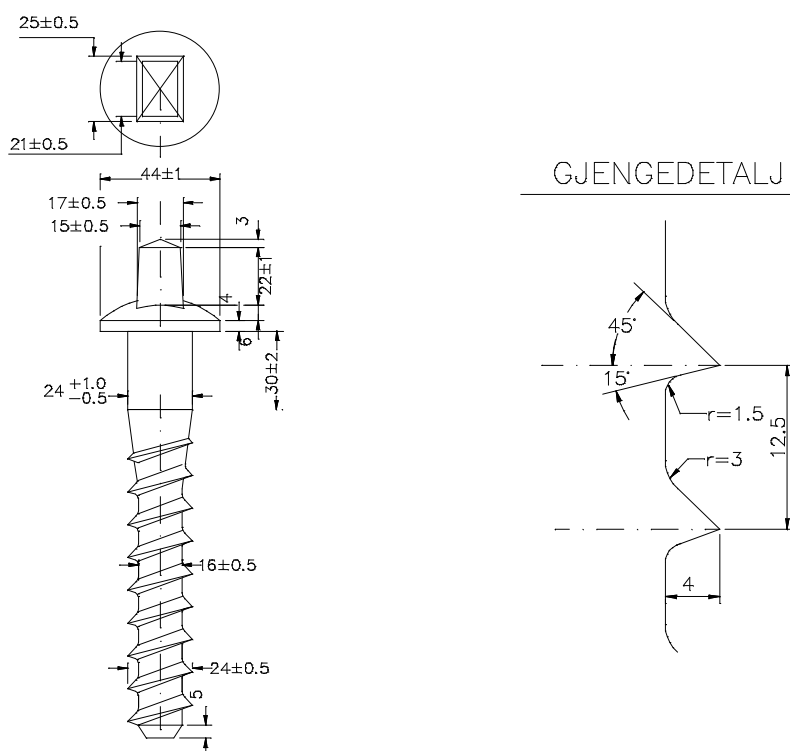

5.3 Svilleskrue for Nabla på tresviller

Tegning: Sk 3141

