

| | | |
|----|--|----|
| 1 | SPENNBETONGSVILLE JBV 97 | 2 |
| 2 | SPENNBETONGSVILLE NSB 95 | 3 |
| 3 | SPENNBETONGSVILLE NSB 93 | 4 |
| 4 | SPENNBETONGSVILLE NSB 90 | 5 |
| 5 | SPENNBETONGSVILLE NSB ENHETSSVILLE..... | 6 |
| 6 | NSB ENHETSSVILLE I SPESIALUTFØRELSE..... | 7 |
| 7 | SPENNBETONGSVILLE TYPE 2 FOR HEY-BACK | 8 |
| 8 | SPENNBETONGSVILLE TYPE 2 FOR PANDROL..... | 9 |
| 9 | SPENNBETONGSVILLE TYPE 2 MED STØPEJERNSANKER..... | 10 |
| 10 | SVILLEANKER | 11 |
| 11 | TRESVILLE..... | 15 |
| 12 | BETONGSVILLE FOR SPORVEKSLER MED PANDROL FASTCLIP/e-clip FESTE.. | 16 |
| 13 | BETONGSVILLE FOR SPORVEKSLER MED PANDROL e-clip/PR-CLIP FESTE..... | 17 |
| 14 | BETONGSVILLE FOR SPORVEKSLER MED DYBLER | 18 |
| 15 | BRUSVILLE 95 | 19 |
| 16 | BRUSVILLE 97 | 20 |
| 17 | BRUSVILLE 90 | 21 |

1 SPENNBETONGSVILLE JBV 97

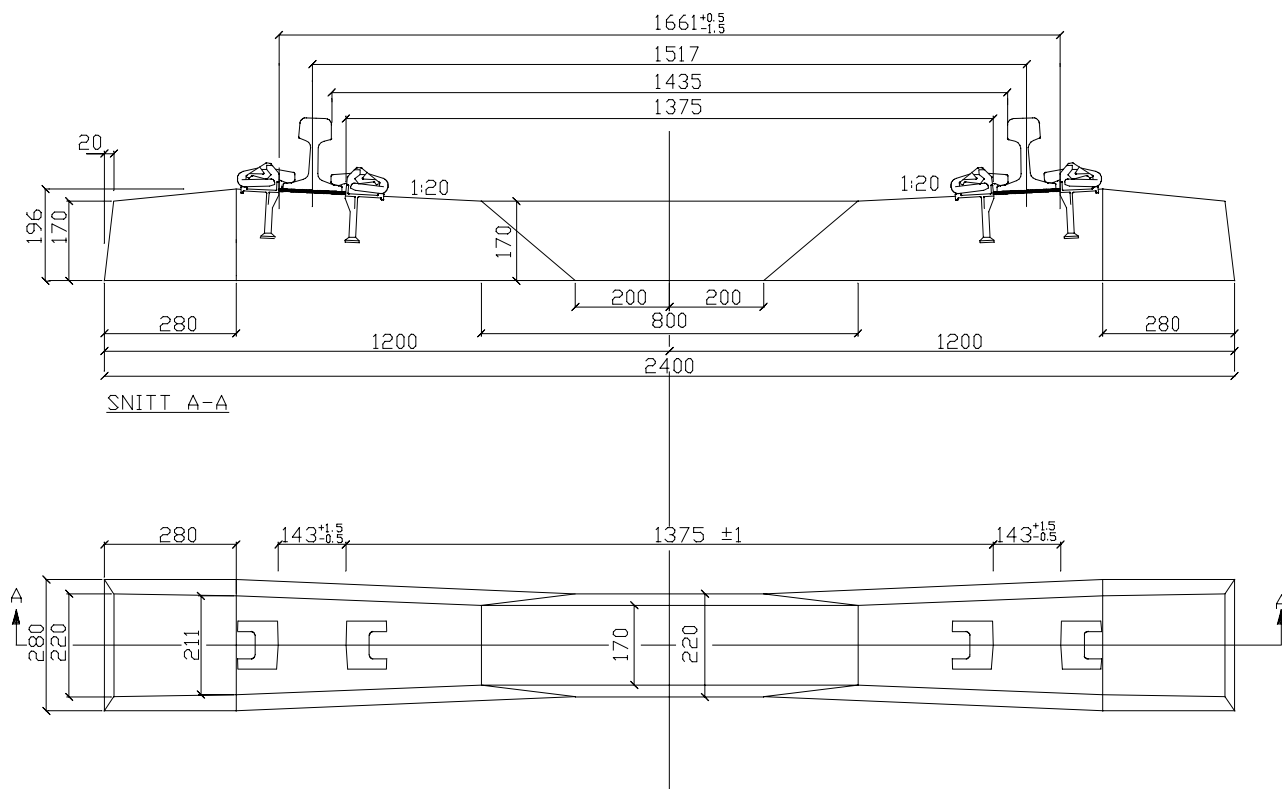

Svillens vekt: 230 kg

Tegning: Sk 3181

Ankeret Sk 3165A er innstøpt i svillen.

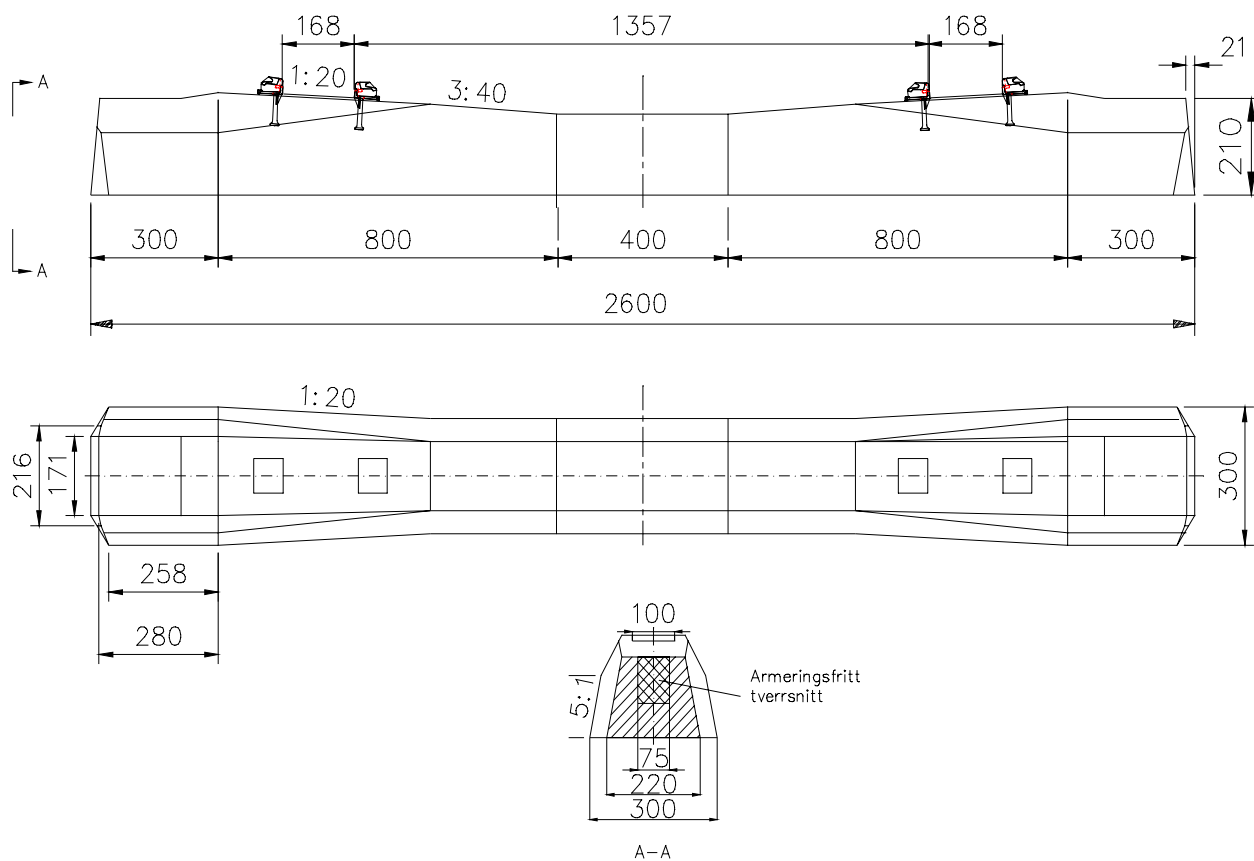
2 SPENNBETONGSVILLE NSB 95

Svillens vekt: 270 kg

Tegning: Sk 3180

Ankeret Sk 3165 er innstøpt i svillen.

3 SPENNBETONGSVILLE NSB 93

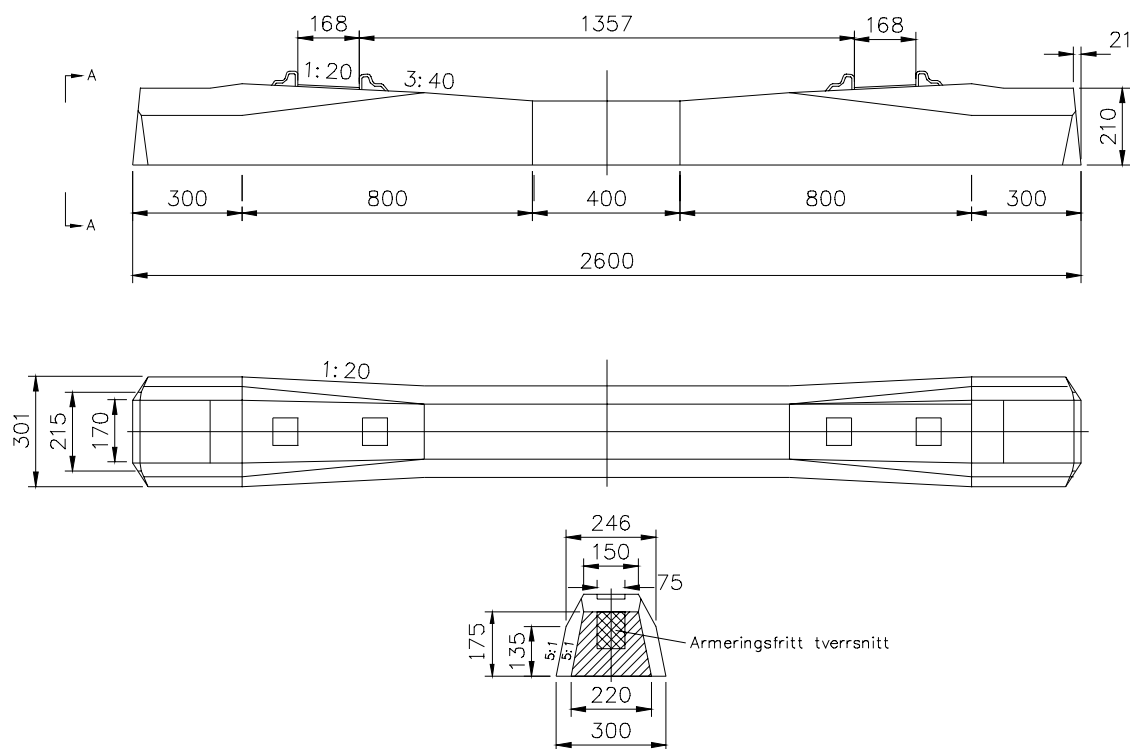

Svillens vekt: 270 kg

Tegning: Sk 3130

Ankeret Sk 3106b er innstøpt i svillen.

4 SPENNBETONGSVILLE NSB 90

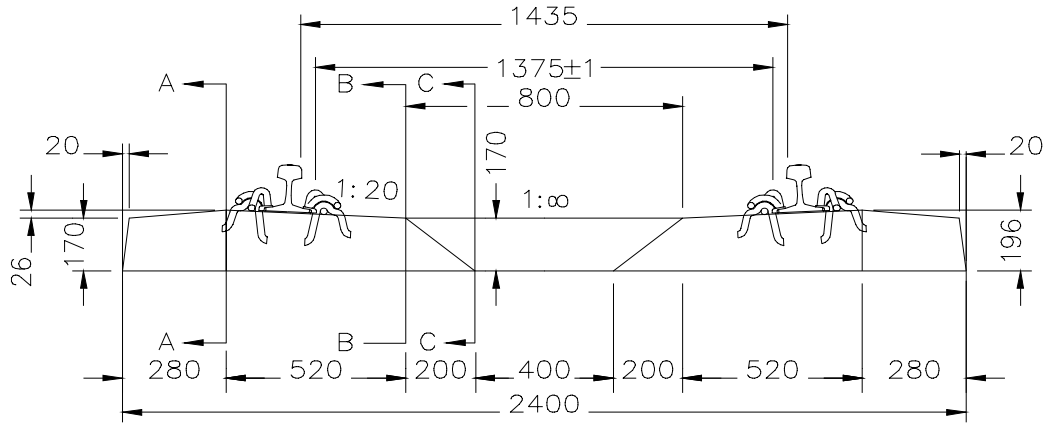

Svillemidte

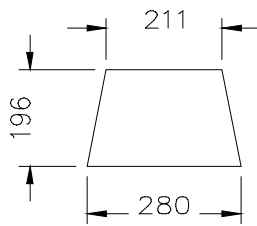
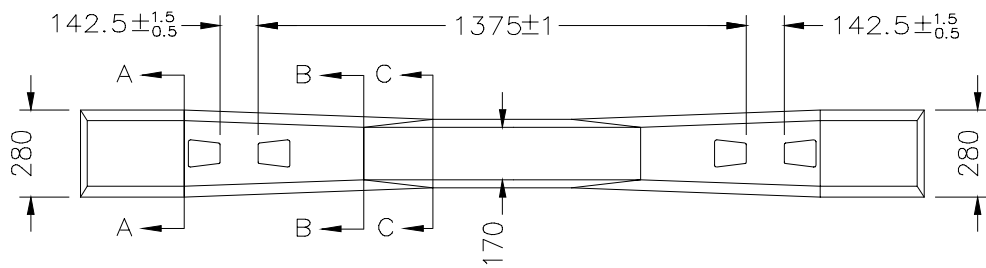

SNITT A-A

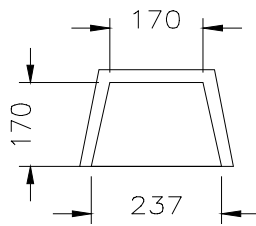

SNITT B-B

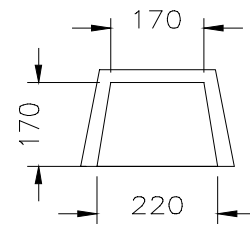

SNITT C-C

Svillens vekt: 230 kg

Tegning: Sk 3105

Ankeret Sk 3106 eller Sk 3106b er innstøpt i svillen.

5 SPENNBETONGSVILLE NSB ENHETSSVILLE

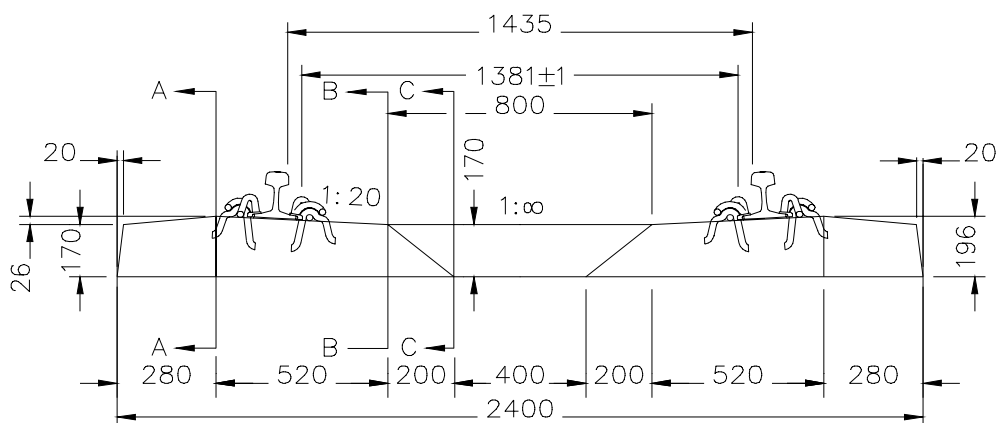

Svillemidte

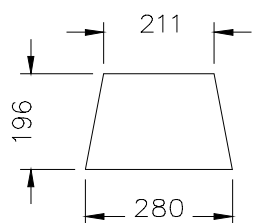
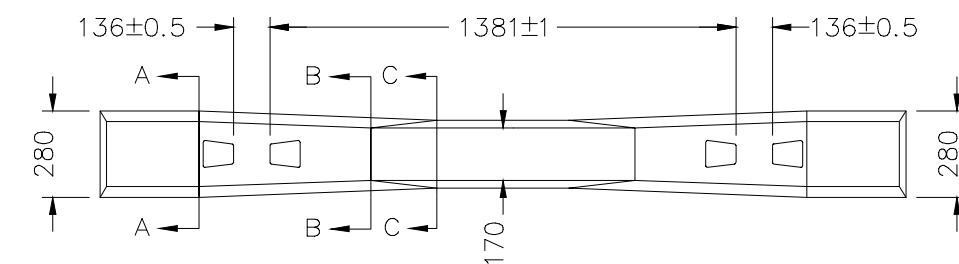

SNITT A-A

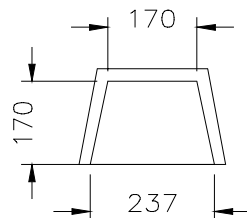

SNITT B-B

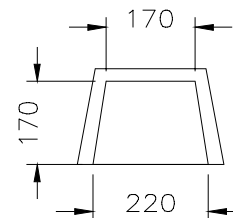

SNITT C-C

Svillens vekt: 230 kg

Tegning: Sk 1619a

Ankeret Sk 1622a er innstøpt i svillen.

6 NSB ENHETSSVILLE I SPESIALUTFØRELSE

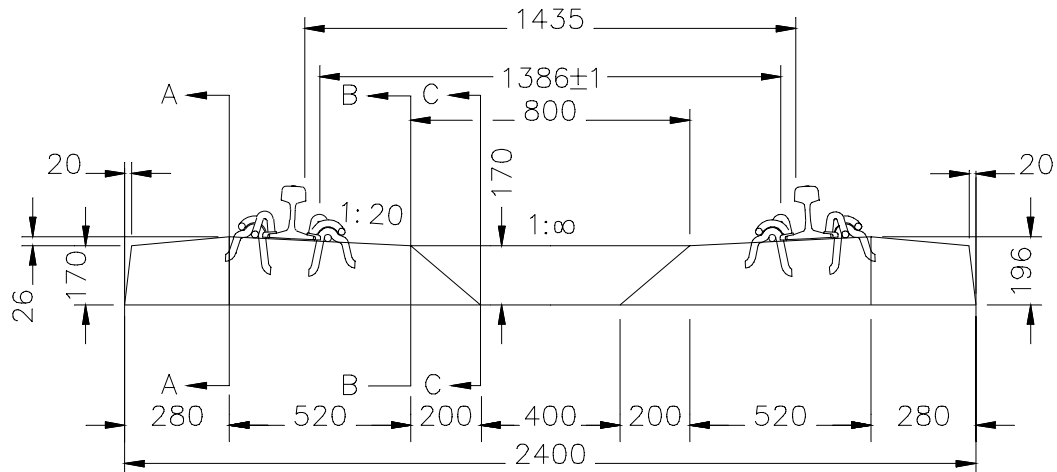

Svillemidte

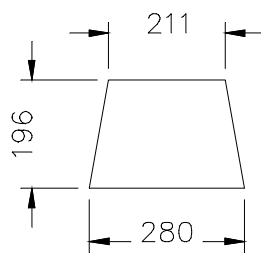
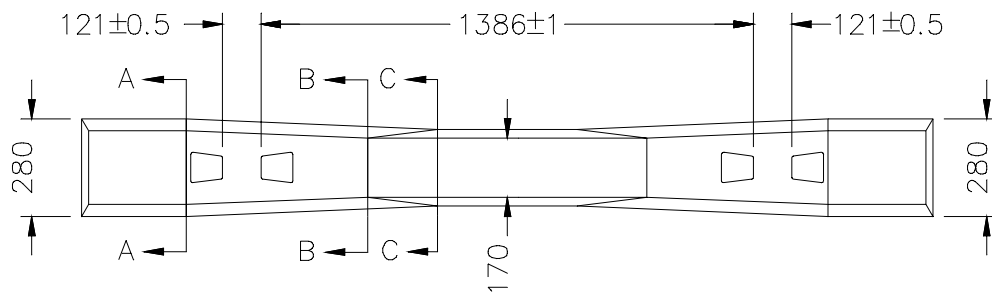

SNITT A-A

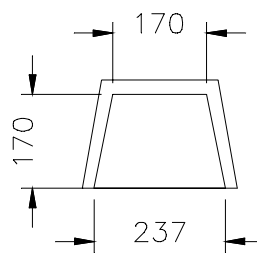

SNITT B-B

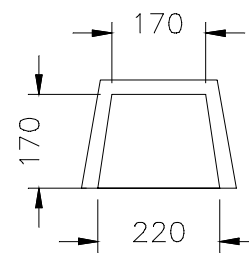

SNITT C-C

Svillens vekt: 230 kg

Sk 1619b

ånkeret Sk 1622a er innstøpt i svillen.

NSB enhetssville i spesialutførelse er lik NSB enhetssville bortsett fra at de innstøpte ankerne er tilpasset skinnprofilene 35 og NSB40.

7 SPENNBETONGSVILLE TYPE 2 FOR HEY-BACK

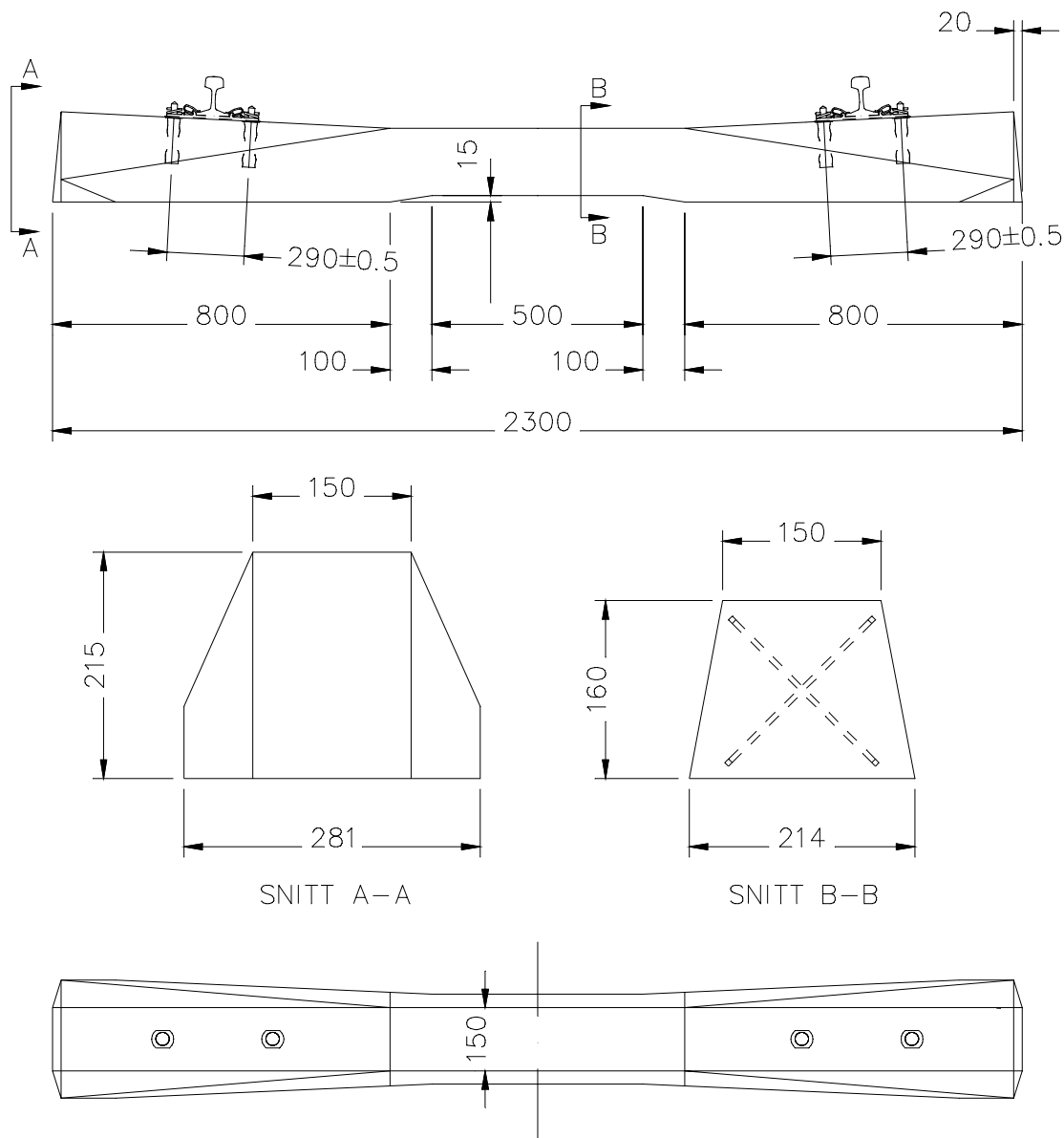

Svillens vekt: 230 kg
 Tegning: Sk 998
 Hey-back plate Sk 972 påmonteres svillen.

8 SPENNBETONGSVILLE TYPE 2 FOR PANDROL

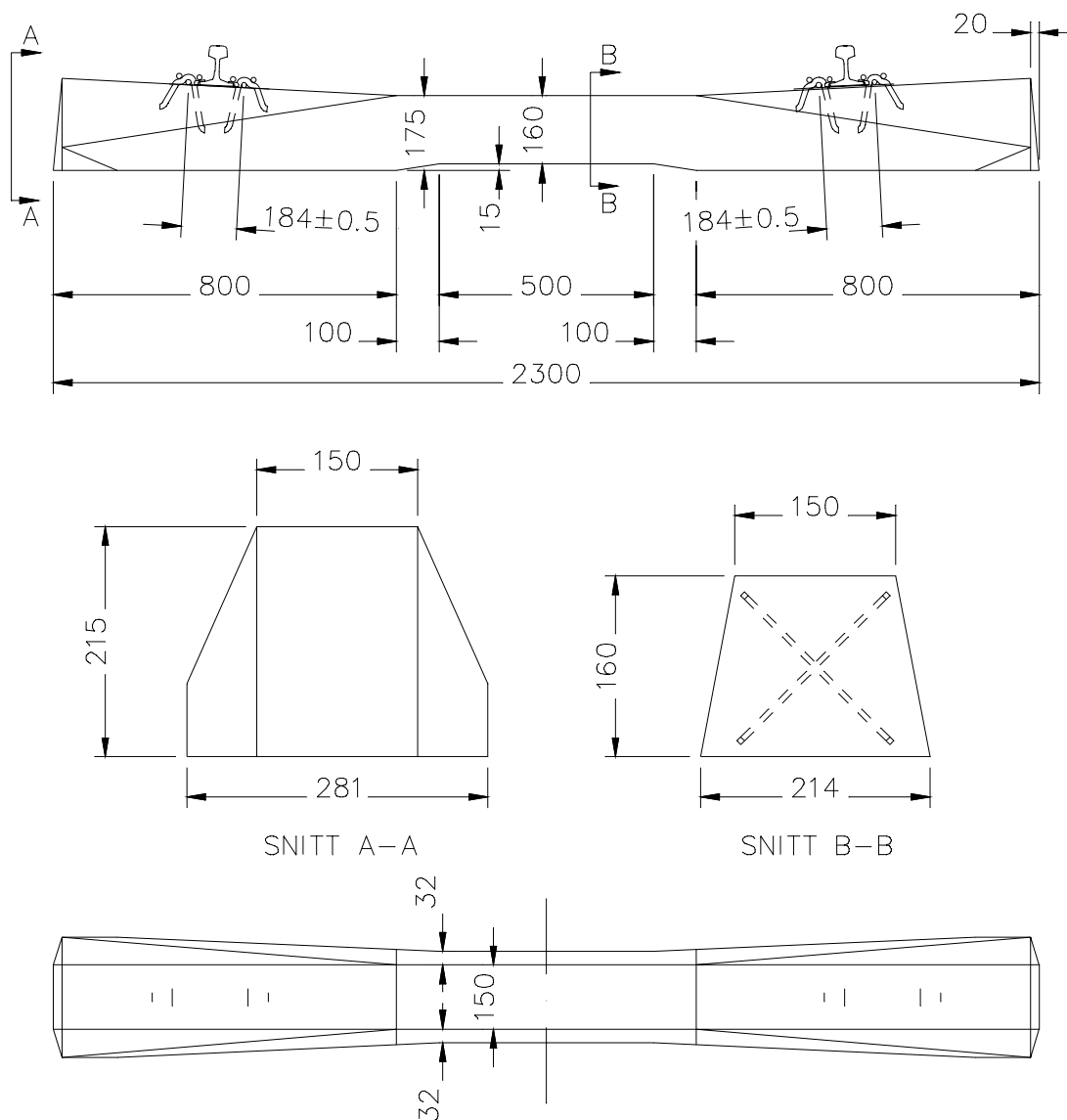

Svillens vekt: 226 kg

Tegning: Sk 1599

Ankeret Sk 1622a er innstøpt i svillen.

9 SPENNBETONGSVILLE TYPE 2 MED STØPEJERNSANKER

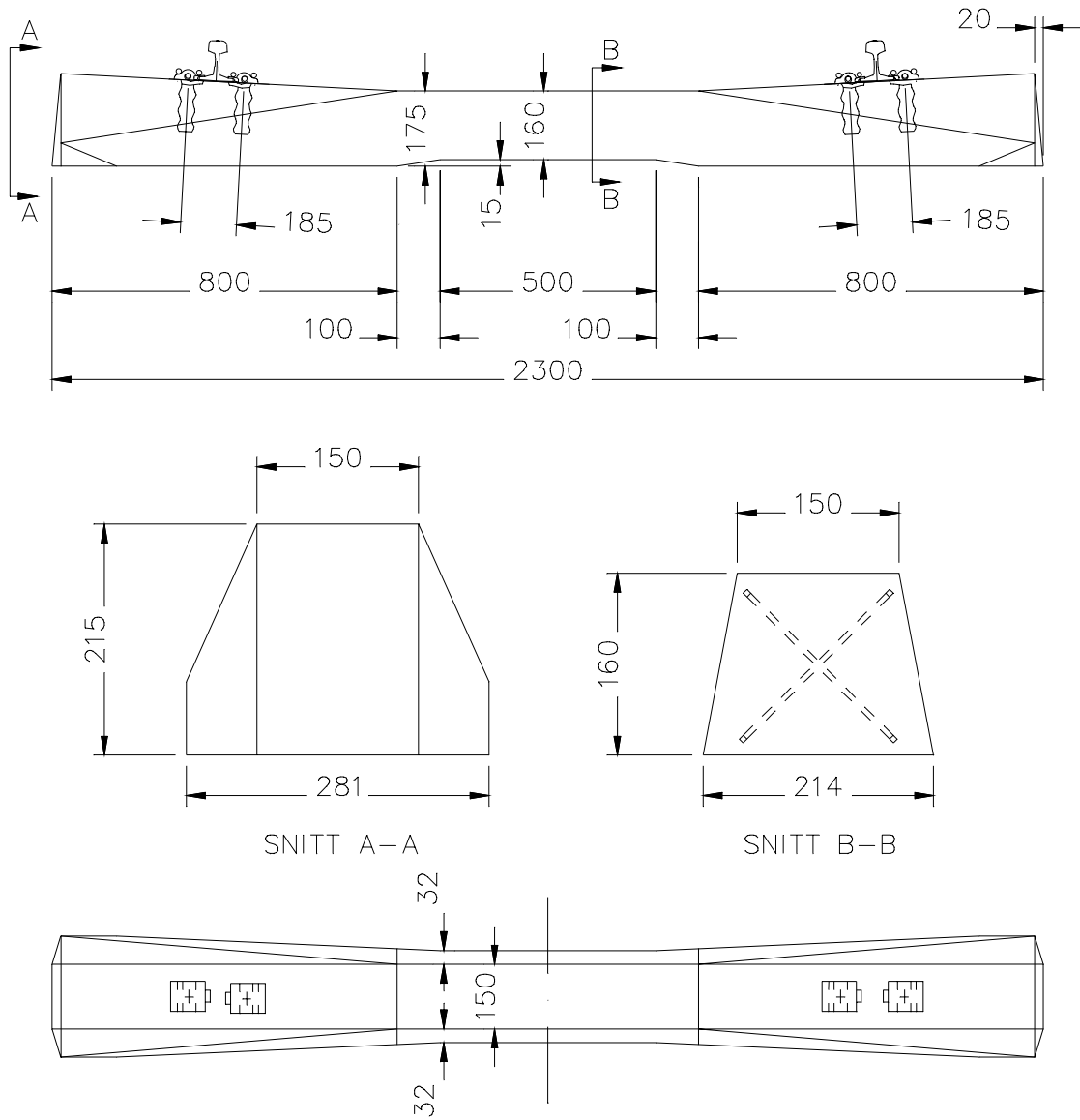

Svillens vekt: 230 kg

Tegning: Sk 1589

Støpejernsankeret Sk 1621 er innstøpt i svillen.

10 SVILLEANKER

Pandrol Fastclip svilleanker for JBV 97 og NSB 95 Tegning: Sk 3165A

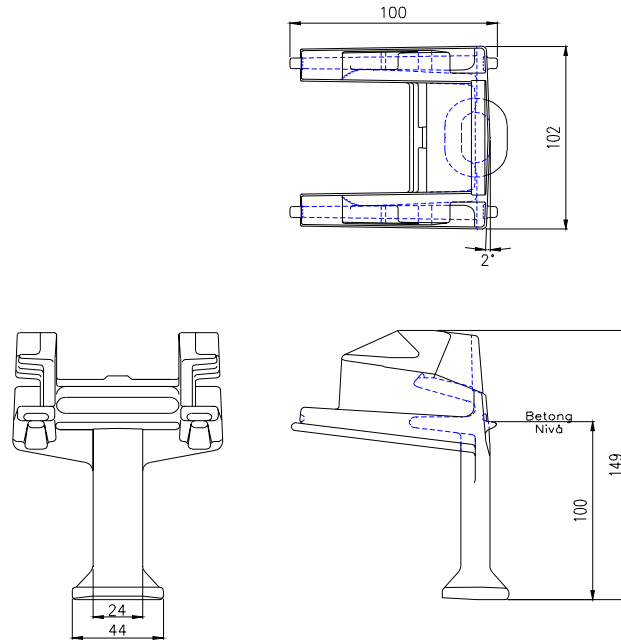

Pandrol anker for NSB 90 og NSB 93 Tegning: Sk 3106b

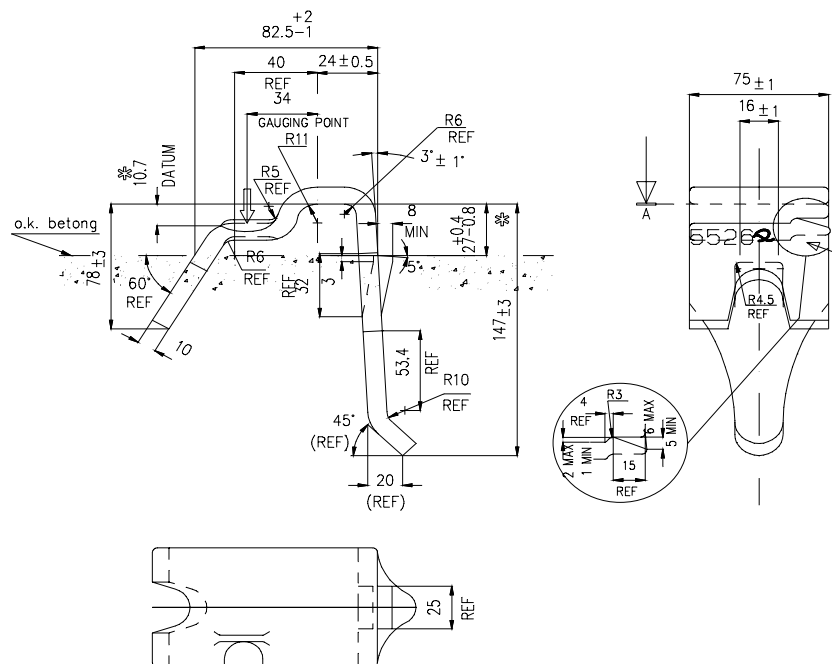

Anker for NSB 90
Tegning: Sk 3106

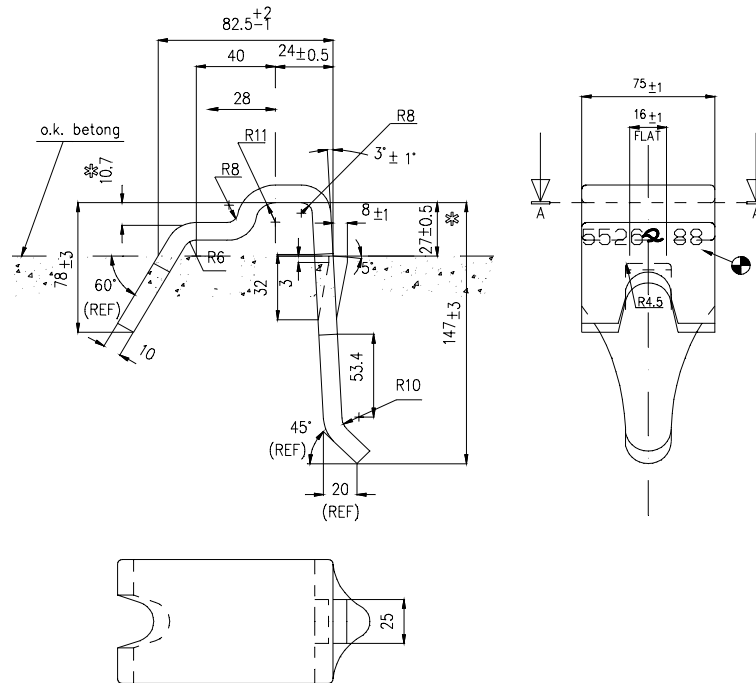

Anker for NSB enhetssville, NSB enhetssville i
spesialutførelse og betongsville type 2
Tegning: Sk 1622a

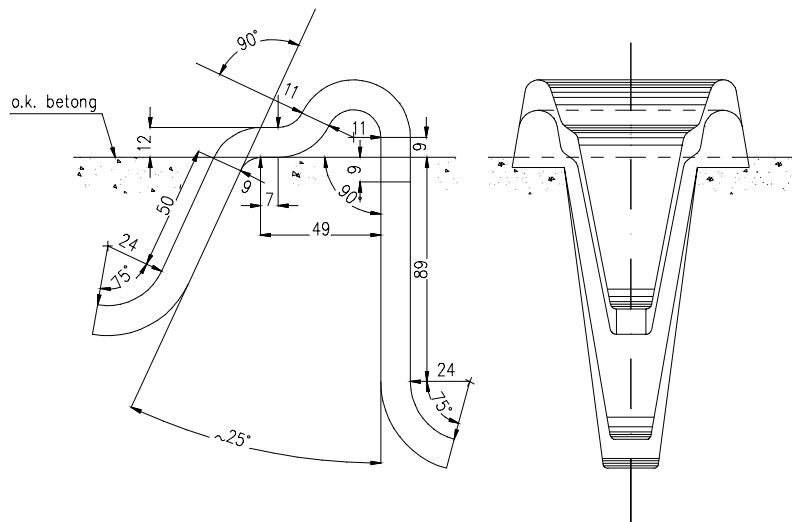

Svilleanker for betongsville type 2
Tegning :Sk 1621

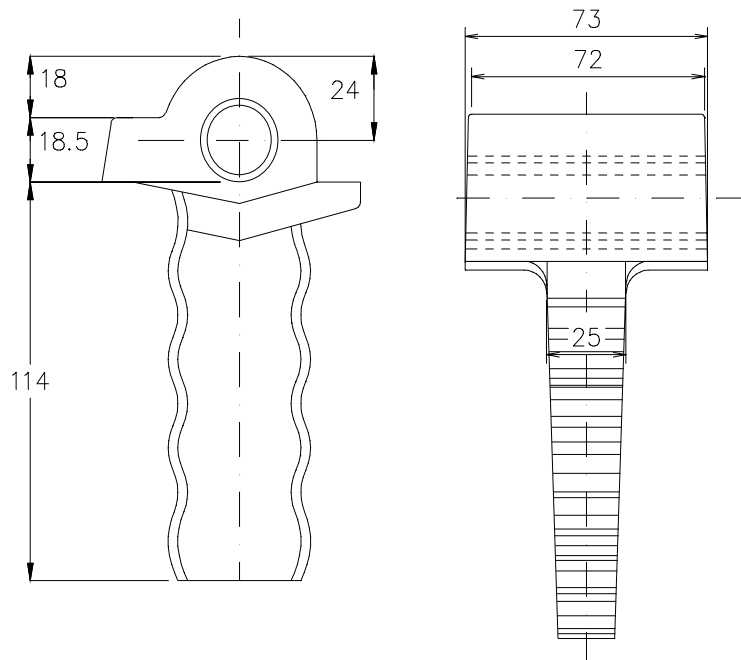

Svilleanker for Pandrol Fastclip i sporveksler
Tegning Sk 3183

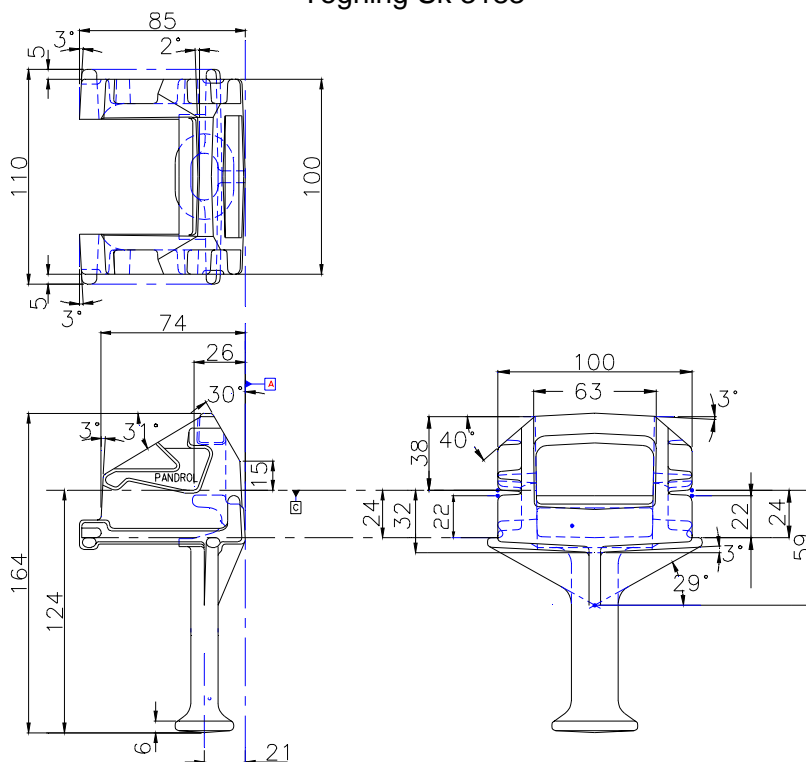

Svilleanker for e-clip i sporveksler

Tegning: Sk 3127

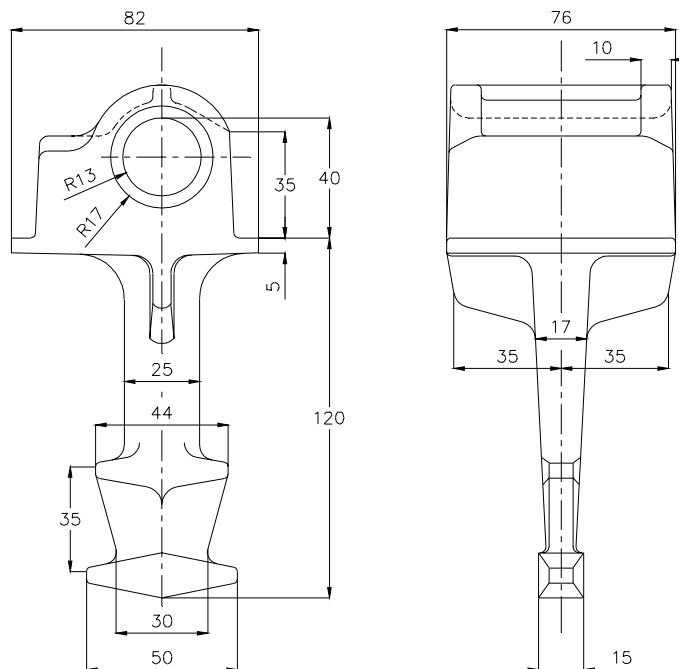

Støpejernsanker for Pandrol PR-clip i sporveksler

Tegning Sk 3126

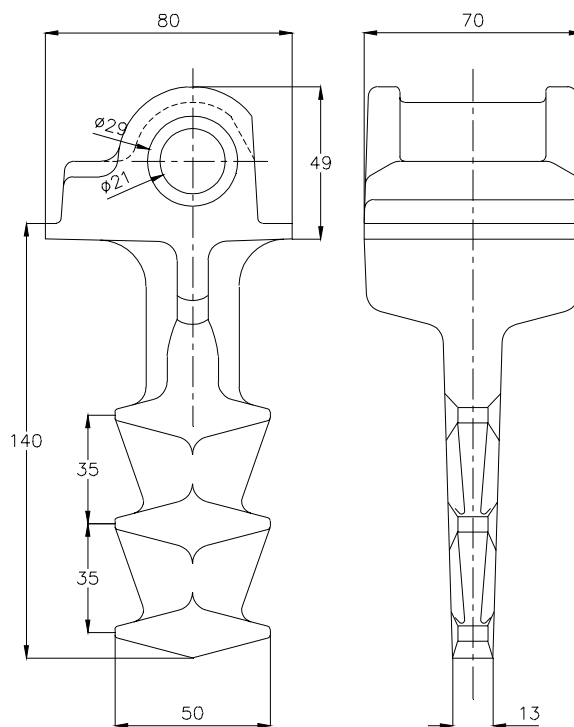

11 TRESVILLE

Type X

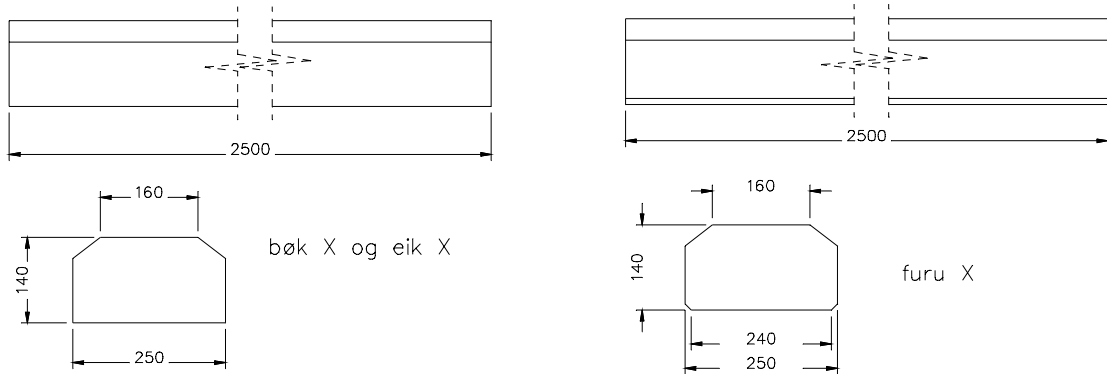

vekt: 56 kg (furu), 80 kg (bøk).

Tegning: Sk 1645

Dobbeltsville

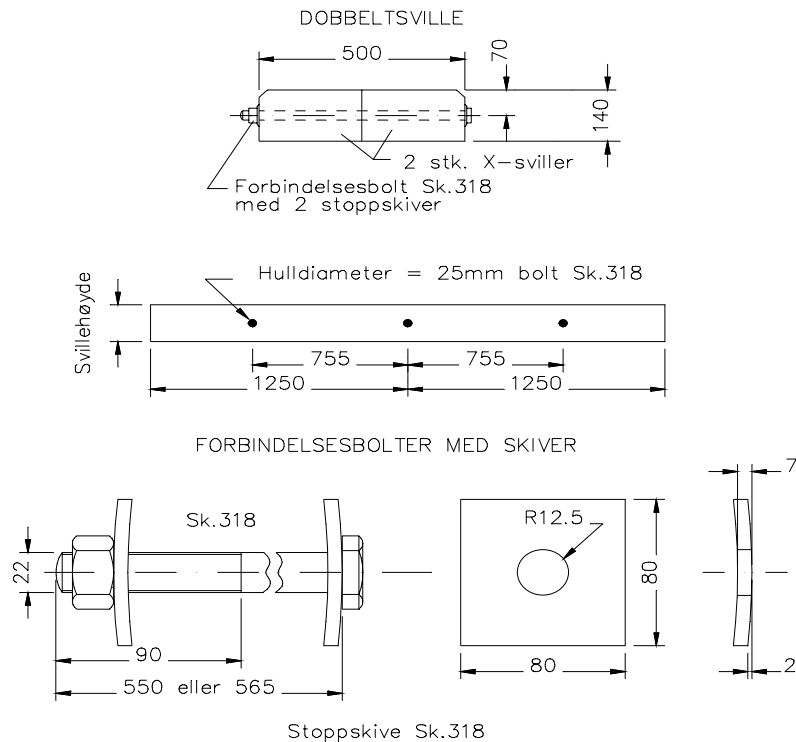

Tegning: Sk 1646

12 BETONGSVILLE FOR SPORVEKSLER MED PANDROL FASTCLIP/e-CLIP FESTE

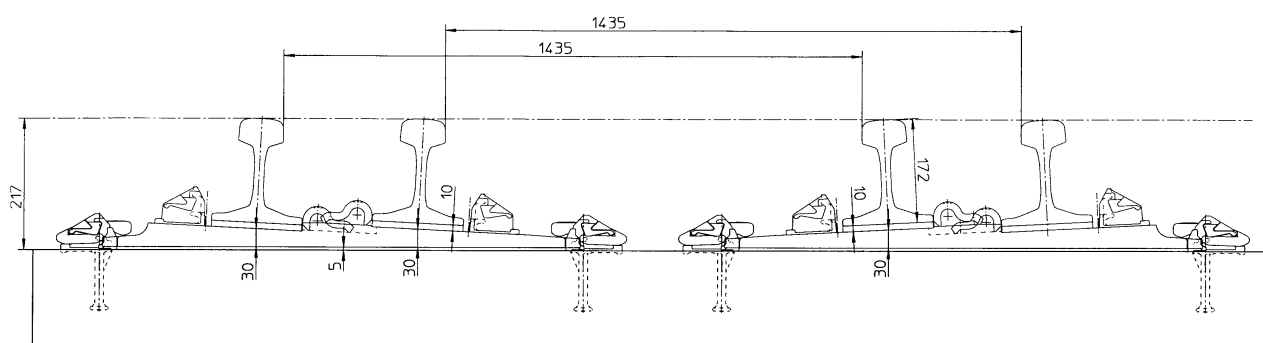

Anker Sk 3183 er innstøpt i betongsvillen.

13 BETONGSVILLE FOR SPORVEKSLER MED PANDROL e-CLIP/PR-CLIP FESTE

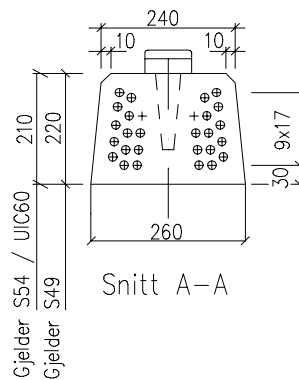
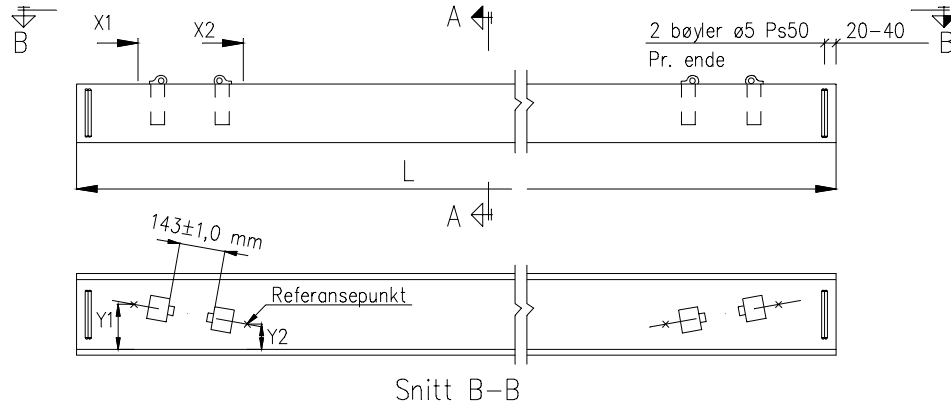

Tegning: Sk 1634b

Anker Sk 3127 er innstøpt i betongsvillen. Ankerne er tilpasset bruk av 10 mm mellomlegg X, Y og L for plassering av innstøpningsdetaljene er gitt i koordinatliste
Figuren viser koordinatene til sentrum av dyblene slik det fremgår av tegning

14 BETONGSVILLE FOR SPORVEKSLER MED DYBLER

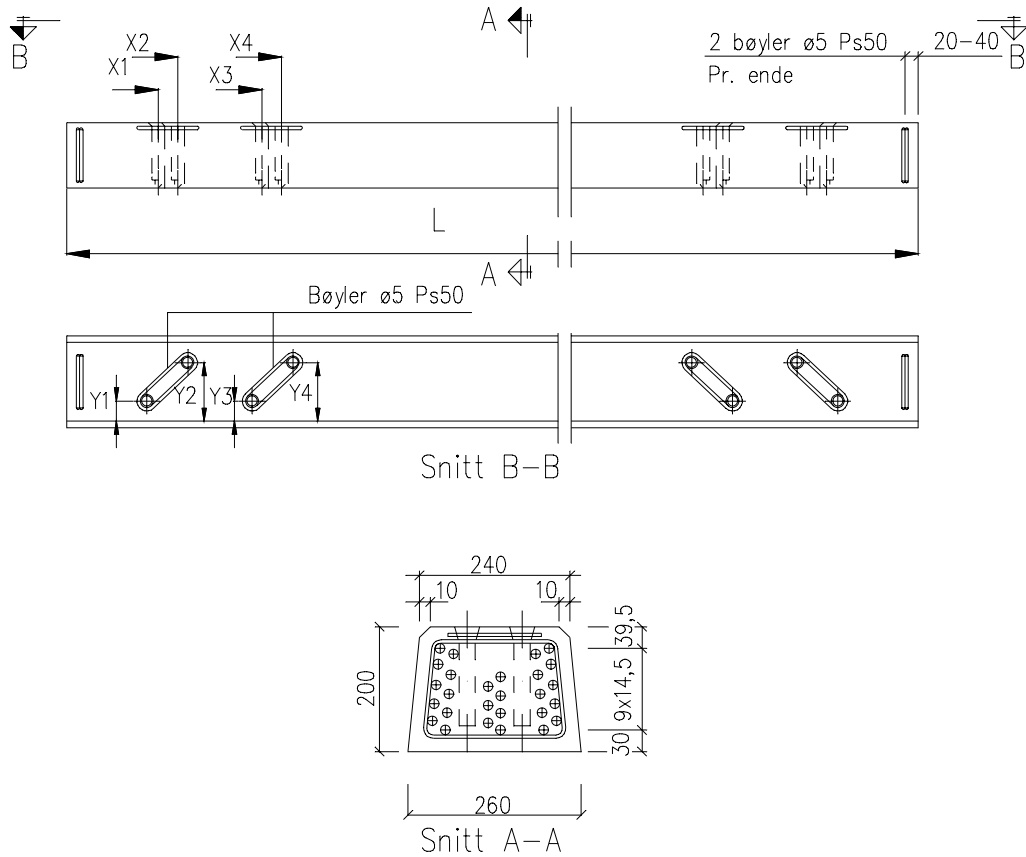

Tegning: Sk 1634a

Plastdybler Sdu 9 er innstøpt i betongsvillen

Svillene har gjennomgående hull for drenering

X, Y og L for plassering av innstøpningsdetaljene er gitt i koordinatliste

Figuren viser koordinatene til sentrum av dyblene slik det fremgår av tegning

15 BRUSVILLE 95

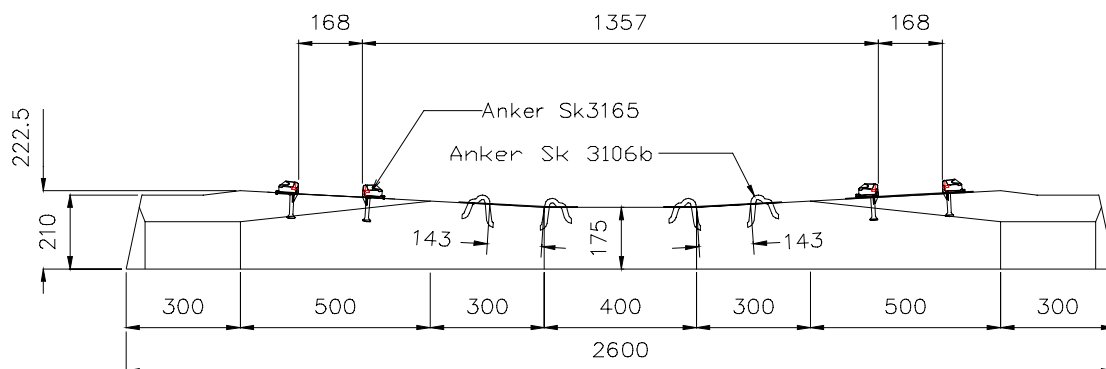

Type 1 – anvendes inne på brua

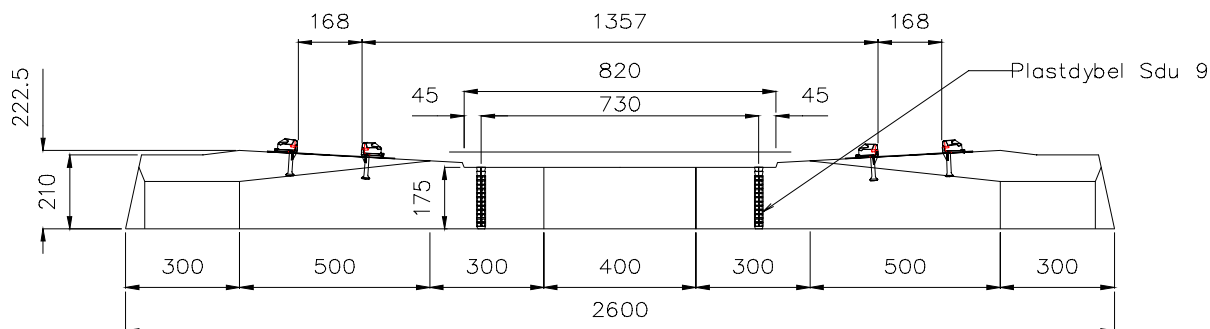

Type 2 – anvendes ved avslutning av ledeskinnene

Tegning: Sk 3186

Brusville 95 er identisk med NSB 95 med unntak av innstøpte anker / dybler for feste av ledeskinner.

16 BRUSVILLE 97

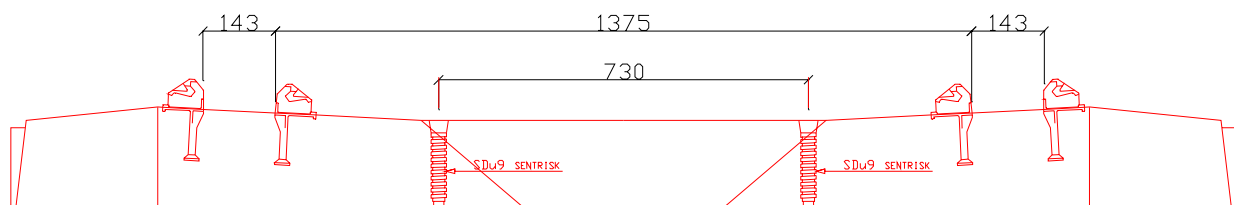
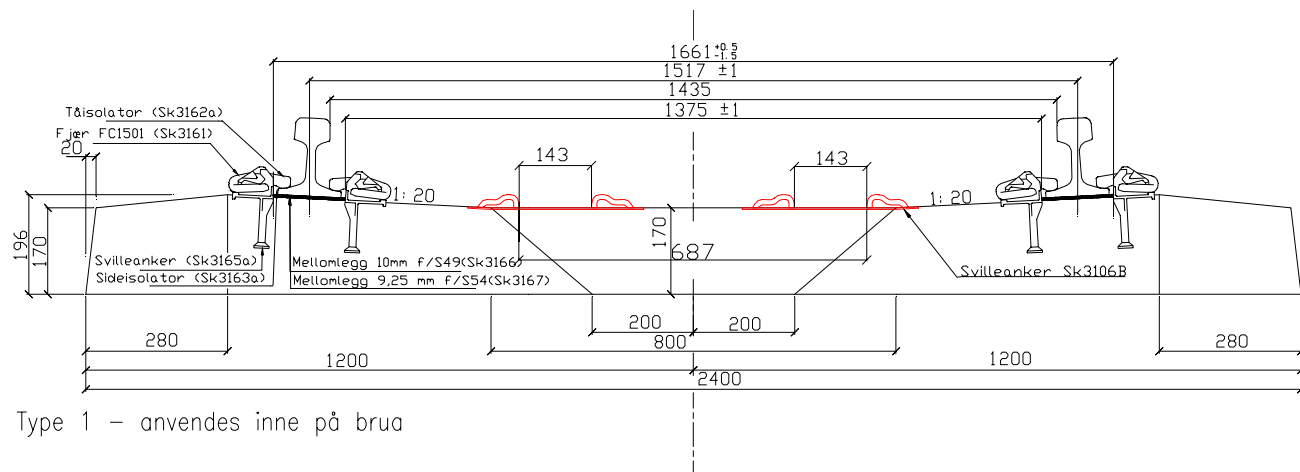

Tegning: Sk 3185

Brusville 95 er identisk med NSB 97 med unntak av innstøpte anker / dybler for feste av ledeskinner.

17 BRUSVILLE 90

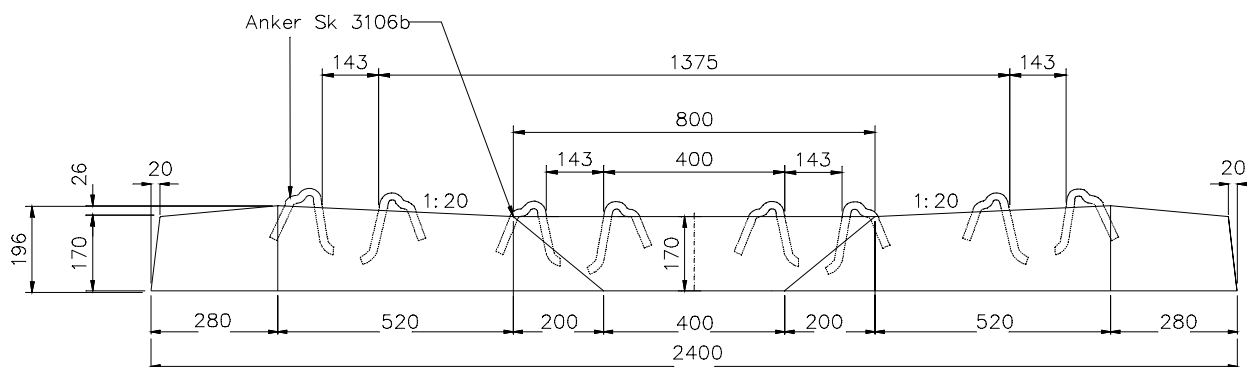

Type 1 – anvendes inne på brua

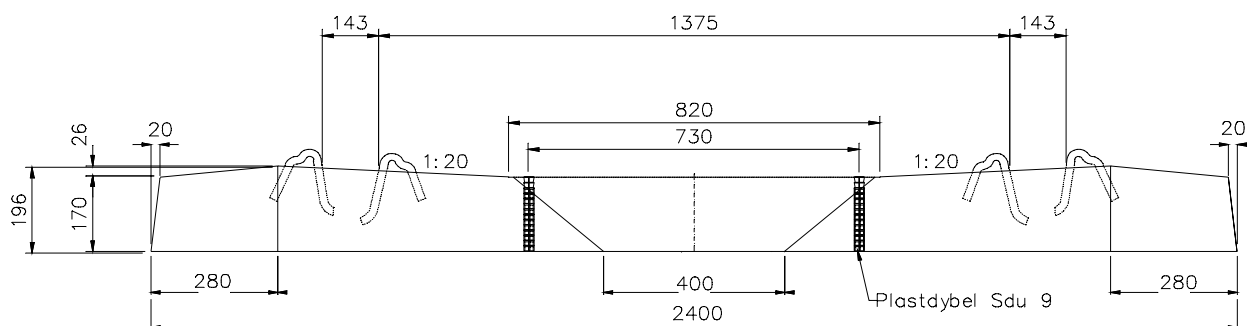

Type 2 – anvendes ved avslutning av ledeskinnene

Tegning: Sk 3124

Brusville 90 er identisk med NSB 90 med unntak av innstøpte anker / dybler for feste av ledeskinner.